

COURSE CODE:	<i>MCE 204</i>
COURSE TITLE:	<i>Engineering Thermodynamics</i>
NUMBER OF UNITS:	<i>3 Units</i>
COURSE DURATION:	<i>Three hours per week</i>

COURSE DETAILS:

Course Coordinator:	Dr Salami Olasunkanmi ISMAILA, ND, BSc, MSc, PhD
Email:	ismailasalami@yahoo.com
Office Location:	Room 1 PG School
Other Lecturers:	None

COURSE CONTENT:

Definition of terms and general concept of systems, surrounding, process, temperature, heat work and energy. First law of thermodynamics and application to open systems. Second law of thermodynamics and application to heat engines. Entropy. First and second laws combined. Perfect gases. Joule-Thompson coefficient. Equilibrium processes. Maxwell's relations. Two phase system. Thermodynamic functions of solution. P.V.T – relationship. Work from heat energy. Refrigeration.

COURSE REQUIREMENTS:

This a compulsory course for all students in the College of Engineering. Students are expected to participate in all course activities and have minimum of 75% attendance to be able to write the final examination.

READING LIST:

1. Cengel Y. A. & Boles M. A. (2006). Thermodynamics: An Engineering Approach. Tata McGraw-Hill, 7 West Patel Nagar, New Delhi 110008.
2. Jones J. B. & Dugan R. E. (2006). Engineering Thermodynamics. Prentice-Hall of India Private Limited, New Delhi-110001.
3. Moran M. J. & Shapiro H.N. (1998). Fundamentals of Engineering Thermodynamics. John Wiley & Sons Ltd., Baffins Lane, Chichester, West Sussex PO19 1UD, England.
4. Osore O.A. (1999). Essentials of Classical Thermodynamics. IPS Educational Press, P.M.B 173, Ilaro, Ogun state, Nigeria.

LECTURE NOTES

1.0 INTRODUCTION

Thermodynamics was obtained from two Greek words namely *thermos* meaning heat and *dynamis* meaning power. Engineering thermodynamics deal with the laws that govern the processes involving the conversion of heat into work and vice-versa. It gives the interrelationship between thermal, mechanical and chemical processes in heat engines and refrigerating engines; studies these processes and properties of these bodies under various physical conditions.

Thermodynamics is the science that deals with heat and work and those properties of substance that bear a relation to heat and work. Thermodynamics is the study of the patterns of energy change. More specifically, thermodynamics deals with (a) energy conversion and (b) the direction of change.

Thermodynamics is an empirical science and is thus based on experimental observation. The principles of thermodynamics are summarized in the form of four laws known as zeroth, first, second, and the third laws of thermodynamics.

The zeroth law of thermodynamics deals with thermal equilibrium and provides a means of measuring temperature.

The first law of thermodynamics deals with the conservation of energy and introduces the concept of internal energy.

The second law of thermodynamics dictates the limits on the conversion of heat into work and provides the yard stick to measure the performance of various processes. It also tells whether a particular process is feasible or not and specifies the direction in which a process will proceed. As a consequence it also introduces the concept of entropy.

The third law defines the absolute zero of entropy.

1.1 Thermodynamic System:

An important concept in thermodynamics is the “system”. A system is the region of the universe under study. A system is separated from the remainder of the universe by a boundary which may be imaginary or not, but which by convention delimits a finite volume. The possible exchanges of work, heat, or matter between the system and the surroundings take place across this boundary. Two types of exchange can occur between system and surroundings: (1) energy exchange (heat, work, friction, radiation, etc.) and (2) matter exchange (movement of molecules across the boundary of the system and surroundings).

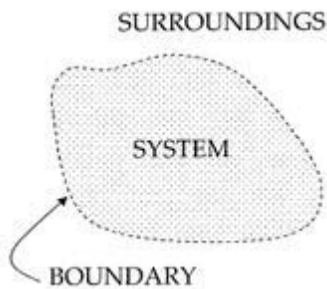

Defining the system and surroundings is arbitrary, but it becomes important when we consider the exchange of energy between the system and surroundings.

Based on the types of exchange which take place or don't take place, five dominant classes of systems may be defined:

There are:

Isolated Systems – matter and energy may not cross the boundary.

Adiabatic Systems – heat may not cross the boundary.

Diathermic Systems - heat may cross boundary.

Closed Systems – matter may not cross the boundary.

Open Systems – heat, work, and matter may cross the boundary.

For isolated systems, as time goes by, internal differences in the system tend to even out; pressures and temperatures tend to equalize, as do density differences. A system in which all equalizing processes have gone practically to completion, is considered to be in a **state** of thermodynamic equilibrium.

1.2 Control Volume

- Control volume is defined as a volume which encloses the matter and the device inside a control surface.
- Every thing external to the control volume is the surroundings with the separation given by the control surface.
- The surface may be open or closed to mass flows and it may have flows from energy in terms of heat transfer and work across it.
- The boundaries may be moveable or stationary.
- In the case of a control surface that is closed to the mass flow, so that no mass can enter or escape the control volume, it is called a **control mass** containing same amount of matter at all times.

1.3 Property

In thermodynamics a property is any characteristic of a system that is associated with the energy and can be quantitatively evaluated. The property of a system should have a definite value when the system is in a particular state. Thermodynamic property is a point function. Properties like volume of a system that depend on the mass of a system are called extensive properties.

Properties like pressure or temperature which do not depend on the system mass are called intensive properties.

The ratio of extensive property to the mass of the system are called specific properties and therefore become intensive properties.

Substance can be found in three states of physical aggregation namely, solid, liquid and vapor which are called its phases.

If the system consists of mixture of different phases, the phases are separated from each other by phase boundary.

The thermodynamic properties change abruptly at the phase boundary, even though the intensive properties like temperature and pressure are identical.

1.4 Thermal Equilibrium

A system is said to be in thermal equilibrium if the state of all bodies composing a thermodynamic state does not change for a long period of time. If there is no external spontaneous factor a system cannot be out of the state of equilibrium

When the property of a system is defined, it is understood that the system is in equilibrium.

If a system is in thermal equilibrium, the temperature will be same throughout the system.

If a system is in mechanical equilibrium, there is no tendency for the pressure to change. In a single phase system, if the concentration is uniform and there is no tendency for mass transfer or diffusion, the system is said to be in chemical equilibrium.

A system which is simultaneously in thermal, mechanical, and chemical equilibrium is said to be in thermal equilibrium.

1.5 Process

A process is path followed by a system in reaching a given final state of equilibrium state starting from a specified initial state.

An actual process occurs only when the equilibrium state does not exist.

An ideal process can be defined in which the deviation from thermodynamic equilibrium is infinitesimal.

All the states the system passes through during a quasi-equilibrium process may be considered equilibrium states.

For non-equilibrium processes, we are limited to a description of the system before the process occurs and after the equilibrium is restored.

Several processes are described by the fact that one property remains constant.

The prefix iso- is used to describe such processes.

A process is said to be reversible if both the system and its surroundings can be restored to their respective initial states by reversing the direction of the process.

Reversible: if the process happens slow enough to be reversed.

Irreversible: if the process cannot be reversed (like most processes).

Isobaric: process done at constant pressure

Isochoric: process done at constant volume

Isothermal: process done at constant temperature

Adiabatic: process where $q=0$

Cyclic: process where initial state = final state

1.6 Internal Energy

The internal energy is associated with the molecular structure and molecular activity of a system.

The molecule as a whole can move in x, y and z directions with respective components of velocities and hence possesses kinetic energy.

There can be rotation of molecule about its center of mass and then the kinetic energy associated with rotation is called rotational energy.

In addition the bond length undergoes change and the energy associated with it is called vibrational energy.

The electron move around the nucleus and they possess a certain energy that is called electron energy.

The microscopic modes of energy are due to the internal structure of the matter and hence sum of all microscopic modes of energy is called the internal energy.

Bulk kinetic energy (KE) and potential energy (PE) are considered separately and the other energy of control mass as a single property (U).

The total energy possessed by the body is given by:

$$E = KE + PE + U$$

1.7 Work

Whenever a system interacts with its surroundings, it can exchange energy in two ways- work and heat.

In mechanics, work is defined as the product of the force and the displacement in the direction of the force.

Work done when a spring is compressed or extended: According to Hooke's law

$$\text{Spring force} = -k(x - x_0)$$

Where k is the spring constant, x_0 is the equilibrium position, and x is the final position. The negative sign shows that the direction of the spring force is opposite the direction of the displacement from x_0 . The external force is equal in magnitude but opposite in sign to the spring force, so

$$\text{External force (force of your hands)} = k(x - x_0).$$

Now, we want to calculate the work done when we stretch the spring from position 1 to position 2.

$$W = F dx = k(x - x_0) d(x - x_0) = \frac{1}{2} k [(x_2 - x_0)^2 - (x_1 - x_0)^2]$$

Work done when a volume is increased or decreased

Consider a gas in a container with a movable piston on top. If the gas expands, the piston moves out and work is done by the system on the surroundings. However, if the gas inside contracts, the piston moves in and work is done by the surroundings on the system. Why would the gas inside contract or expand?

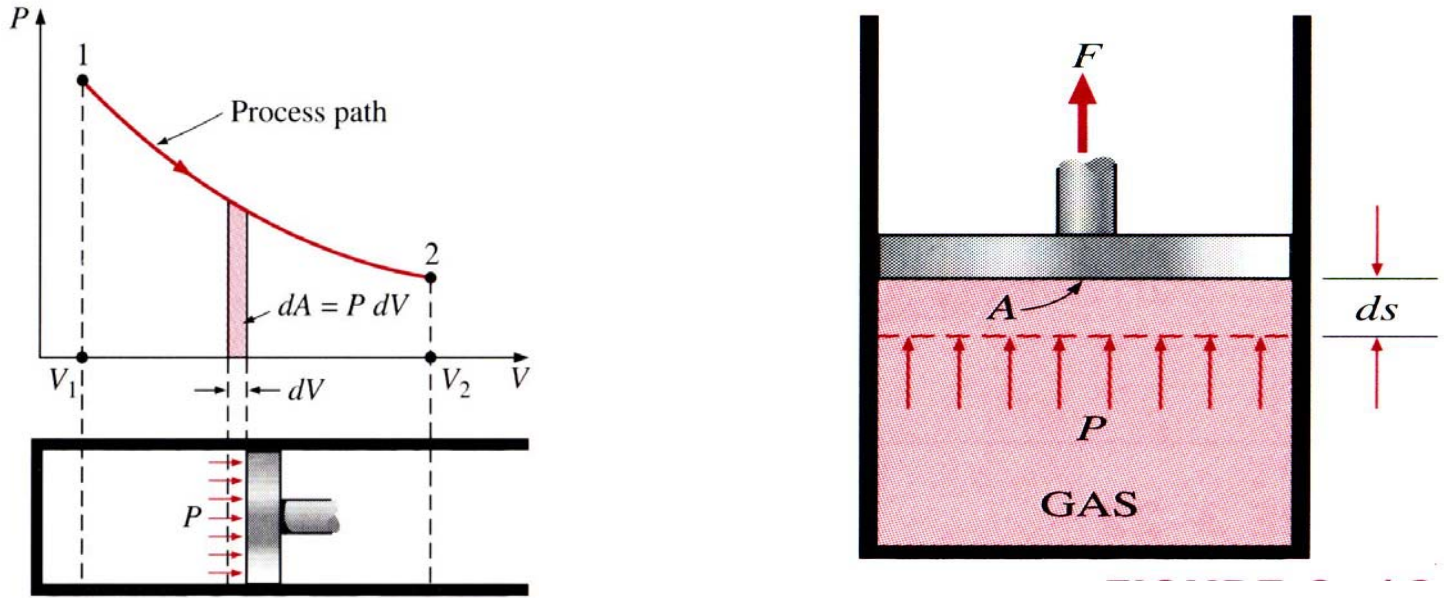

It would if the external pressure, P_{ex} , and the internal pressure, P_{in} , were different. To calculate the work done in moving the piston, we know that the force = pressure times area and then work equals pressure times area times distance or work equals pressure times the change in volume. So, $W =$ the integral of $(P_{ex}) dV$

The differential work done (dW) associated with a differential displacement (ds) is given by

$$dW = F ds$$

For a piston cylinder assembly,
 $dW = F ds = PA (ds) = P dV$

If the gas is allowed to expand reversibly from the initial pressure P to final pressure P , then the work done is given by

$$W = \int p dV$$

The integral represents the area under the curve on a pressure versus volume diagram. Therefore the work depends on the path followed and work is a path function and hence not a property of the system.

The above expression does not represent work in the case of an irreversible process.

The thermodynamic definition of work is “ Work is said to be done by a system on the surrounding if the sole effect external to the system could be reduced to the raising of a mass through a distance”.

1.8 Heat

Heat like work, is a form of energy.

The energy transfer between a system and its surroundings is called heat if it occurs by virtue of the temperature difference across the boundary.

The two modes of energy transfer – work and heat- depend on the choice of the system.

Heat energy moves from a hotter body to a colder body upon contact of the two bodies.

If two bodies at different temperatures are allowed to remain in contact, the system of two bodies will eventually reach a thermal equilibrium (they will have the same temperature).

A body never contains heat. Rather heat is a transient phenomenon and can be identified as it crosses the boundary.

1.9 The Parameters of State

The physical state of a system is completely described certain quantities that determines the given state. These quantities are called the parameters of state.

Once a sufficient number of properties are specified, the rest of the properties assume some values automatically. A number of quantities can serve as parameters of state and examples are specific volume, enthalpy, entropy, pressure, temperature etc.

The state of a simple compressible system is completely specified by two independent, intensive properties.

The system is called a **simple compressible system** in the absence of electrical, magnetic, gravitational, motion, and surface tension effects.

The state of a body requires that the two properties specified be independent to fix the state.

Two properties are independent if one property can be varied while the other one is held constant.

Temperature and specific volume, for example, are always independent properties, and together they can fix the state of a simple compressible system.

Thus, temperature and pressure are not sufficient to fix the state of a two-phase system.

Otherwise an additional property needs to be specified for each effect that is significant.

An additional property needs to be specified for each other effect that is significant.

1.10 Reversible and Irreversible Processes

A reversible process occurs when a system changes its state and passes through a continuous series of thermodynamic states such that both the system and its surroundings can be restored to their original state. For a system to undergo a reversible process, it must have passed through series of thermodynamic equilibrium state points that can be joined up to form a continuous line on a diagram of properties.

2.0 ZEROth LAW OF THERMODYNAMICS

We cannot assign numerical values to temperatures based on our sensations alone. Furthermore, our senses may be misleading.

Several properties of material changes with temperature in a repeatable and predictable way, and this form the basis of accurate temperature measurement.

The commonly used mercury-in-glass thermometer for example, is based on the expansion of mercury with temperature.

Temperature is also measured by using several other temperature dependant properties.

Two bodies (eg. Two copper blocks) in contact attain thermal equilibrium when the heat transfer between them stops.

The equality of temperature is the only requirement for thermal equilibrium.

The **Zeroth Law of Thermodynamics states that**: If two bodies are in thermal equilibrium with a third body, they are also in thermal equilibrium with each other. This obvious fact cannot be concluded from the other laws of thermodynamics, and it serves as a basis of temperature measurement.

By replacing the third body with a thermometer, the zeroth law can be restated *two bodies are in thermal equilibrium if both have the same temperature reading even if they are not in contact*

The zeroth law was first formulated and labeled by R.H. Fowler in 1931.

2.1 Ideal and Real Gases

Pure Substance: A pure substance is one that has a homogeneous and invariable chemical composition. It may exist in more than one phase but chemical composition is the same in all phases.

Some times the mixture of gases, such as air is considered a pure substance as long as there is no change of phase. Further our emphasis will be on simple compressible substances

Early experiments on the **variables of state** (such as T, P, V, and n) showed that only two of these variables of state need to be known to know the state of a sample of matter.

Extensive variables: depend on the amount of substance present. Examples include the volume, energy, enthalpy, and heat capacity.

Intensive variables: do not depend on the amount of substance present. Examples include the temperature and pressure.

Equations of State

An equation of state is an equation which relates the variables of state (T, P, V, and n). It's particularly useful when you want to know the effect of a change in one of the variables of state

Solids and Liquids: If the pressure on a solid or liquid is increased, the volume does not change much. If the temperature is increased, the volume doesn't change much either. Therefore, an appropriate equation of state describing such systems would be: $V(T,P) = \text{constant}$.

Gases: In contrast, changing the pressure or temperature of a gas will have an easily observable effect on the volume of that gas. For an **ideal gas** (no intermolecular interactions and no molecular volume) an appropriate equation of state would be: $V(T,P,n) = (nRT)/P$.

There are many equations of state describing **real gases**. These equations take in consideration molecular volume and interactions. The most well-known such equations is probably the Van der Waals equation.

Ideal and real gases

An ideal gas is one which follows the ideal gas equation of state, namely

$$PV = (m/M) (MR) T = n R_u T$$

The universal gas constant has a value of 8.314 J/mol K or kJ/kmol K and is related to the specific gas constant by the relation $R_u = (R /M)$

The ideal gas equation of state can be derived from the kinetic theory of gases where the following assumptions are made:

1. The molecules are independent of each other. In other words, there are no attractive forces between the molecules.
2. The molecules do not occupy any volume. That is the volume occupied by the molecules is quite negligible compared to the volume available for motion of the molecules.

The internal energy of an ideal gas is a function of temperature only and is independent of pressure and volume. That is,

$$u = u(T)$$

$$(\partial u / \partial P)_T = 0, (\partial u / \partial v)_T = 0$$

2.2 Enthalpy and specific heat

$$h = u + Pv$$

For an ideal gas $u = u(T)$ only and $PV = mRT$ and hence $h = h(T)$ only.

The specific heat at constant volume is defined as the amount of energy transferred as heat at constant volume, per unit mass of a system to raise its temperature by one degree. That is,

$$C_v = (dq/dT)_v$$

The specific heat at constant pressure is defined as the energy transferred as heat at constant pressure, per unit mass of a substance to raise its temperature by one degree. That is $C_p = (dq/dT)_p$

For a constant pressure process $dq = du + dw = du + Pd v = du + Pd v + v dP$ (since $dP=0$ for a constant pressure process)

$$\text{Or } dq = du + d(Pv) = d(U + Pv) = dh$$

$$\text{or } dq = dh$$

$$C_p = (\partial h / \partial T)_p$$

The ratio of specific heat (γ) is given by

$$\gamma = C_p / C_v$$

For mono-atomic ideal gases $\gamma = 1.67$ and for diatomic gases $\gamma = 1.4$.

Relation between two specific heats:

The two specific heats are related to each other.

$$h = u + Pv \text{ or } dh = du + d(Pv)$$

For an ideal gas, the above equation reduces to

$$dh = du + d(RT) = du + RdT \text{ or}$$

$$dh/dT = du/dT + R \text{ or } C_p = C_v + R$$

$$\text{or } C_p - C_v = R \text{ for an ideal gas.}$$

$$\gamma = C_p / C_v \text{ or } C_p = R/(\gamma - 1) \text{ and } C_v = R\gamma/(\gamma - 1)$$

Real gases:

The ideal gas law is only an approximation to the actual behavior of gases.

At high densities, that is at high pressures and low temperatures, the behavior of actual or real gases deviate from that predicted by the ideal gas law. In general, at sufficiently low pressures or at low densities all gases behave like ideal gases.

Tables of Thermodynamic Properties

Tables of thermodynamic properties of many substances are available, and in general, all these have same form.

Steam tables are selected because steam is used extensively in power plants and industrial processes.

The steam tables provide the data of useful thermodynamic properties like T, P, v, u, h and s for saturated liquid, saturated vapor and superheated vapor.

Since the properties like internal energy, enthalpy and entropy of a system cannot be directly measured; they are related to change in the energy of the system.

Hence one can determine Δu , Δh , Δs , but not the absolute values of these properties. Therefore it is necessary to choose a reference state to which these properties are arbitrarily assigned some numerical values.

For water, the triple point ($T = 0.01^\circ \text{C}$ and $P = 0.6113 \text{ kPa}$) is selected as the reference state, where the internal energy and entropy of saturated liquid are assigned a zero value.

In the saturated steam tables, the properties of saturated liquid that is in equilibrium with saturated vapor are presented.

During phase transition, the pressure and temperature are not independent of each other. If the temperature is specified, the pressure at which both phases coexist in equilibrium is equal to the saturation pressure.

Hence, it is possible to choose either temperature or pressure as the independent variable, to specify the state of two-phase system.

Depending on whether the temperature or pressure is used as the independent variable, the tables are called temperature or pressure tables.

The two phases- liquid and vapor can coexist in a state of equilibrium only up to the critical point.

Therefore the listing of the thermodynamic properties of steam in the saturated steam tables ends at the critical point (374.15° C and 212.2 bar).

If the steam exists in only one phase (superheated steam), it is necessary to specify two independent variables, pressure and temperature, for the complete specification of the state. In the superheated steam tables, the properties- v , u , h , and s - are tabulated from the saturation temperature to some temperature for a given pressure.

The thermodynamic properties of a liquid and vapor mixture can be evaluated in terms of its quality. In particular, the specific volume, specific internal energy, specific enthalpy and specific entropy of a mixture of quality X are given by

$$v = (1-X)v_f + Xv_g, u = (1-X)u_f + Xu_g, h = (1-X)h_f + Xh_g = h_f + Xh_{fg}, s = (1-X)s_f + Xs_g$$

where $h_{fg} = h_g - h_f =$ latent heat of vaporization.

3.0 FIRST LAW OF THERMODYNAMICS

The first law of thermodynamics is the thermodynamic expression of the **law of conservation of energy**. This law simply stated by saying that “energy can not be created or destroyed” or that “the energy of the universe is constant”. This law can be stated for a system (control mass) undergoing a cycle or for a change of state of a system.

Stated for a system undergoing a cycle, the cyclic integral of the work is proportional to the cyclic integral of the heat.

Mathematically stated, for a control mass undergoing a cyclic process such as in Joule’s experiment and for consistent set of units

$$\int dQ_{\text{from system}} = \int dW_{\text{on system}}$$

$$\text{or } \int dQ_{\text{from system}} - \int dW_{\text{on system}} = 0$$

The important thing to remember is that the first law states that the energy is conserved always.

Sign convention The work done by a system on the surroundings is treated as a positive quantity.

Similarly, energy transfer as heat to the system from the surroundings is assigned a positive sign. With the sign convention one can write,

$$\int dQ = \int dW$$

3.1 Consequences of the first law

Suppose a system is taken from state 1 to state 2 by the path 1-a-2 and is restored to the initial state by the path 2-b-1, then the system has undergone a cyclic process 1-a-2-b-1. If the system is restored to the initial state by path 2-c-1, then the system has undergone the cyclic change 1-a-2-c-1. Let us apply the first law of thermodynamics to the cyclic processes 1-a-2-b-1 and 1-a-2-c-1 to obtain

$$\int_{1-a-2} dQ + \int_{2-b-1} dQ - \int_{1-a-2} dW - \int_{2-b-1} dW = 0$$

$$\int_{1-a-2} dQ + \int_{2-c-1} dQ - \int_{1-a-2} dW - \int_{2-c-1} dW = 0$$

Subtracting, we get

$$\int_{2b1} dQ - \int_{2c1} dQ - (\int_{2b1} dW - \int_{2c1} dW) = 0$$

We know that the work is a path function and hence the term in the bracket is non-zero. Hence we find

$$\int_{2b1} dQ = \int_{2c1} dQ$$

That is heat is also a path function.

3.2 Energy is a property of the system

By rearranging we can have

$$\int_{2b1} (dQ - dW) = \int_{2c1} (dQ - dW)$$

It shows that the integral is the same for the paths 2-b-1 and 2-c-1, connecting the states 2 and 1. That is, the quantity $\int (dQ - dW)$ does not depend on the path followed by a system, but depends only on the initial and the final states of the system. That is $\int (dQ - dW)$ is an exact differential of a property. This property is called energy (E). It is given by

$$dE = dQ - dW$$

$$E = KE + PE + U$$

where U is the internal energy. Therefore,

$$dE = d(KE) + d(PE) + dU = dQ - dW$$

Quite often in many situations the KE or PE changes are negligible.

$$dU = dQ - dW$$

An isolated system does not exchange energy with the surroundings in the form of work as well as heat. Hence $dQ = 0$ and $dW = 0$. Then the first law of thermodynamics reduces to $dE = 0$ or $E_2 = E_1$ that is energy of an isolated system remains constant.

3.3 Perpetual Motion Machine of the first kind

An imaginary device that delivers work continuously without absorbing energy from the surroundings is called a Perpetual Motion machine of the first kind. Since the device has to deliver work continuously, it has to operate on a cycle. If such a device does not absorb energy from its surroundings $\int dQ = 0$. From the first law, it can be observed that $\int dW = 0$, if $\int dQ = 0$. Therefore such a device is impossible from first law of thermodynamics.

3.4 First law analysis of non-flow processes

The first law of thermodynamics can be applied to a system to evaluate the changes in its energy when it undergoes a change of state while interacting with its surroundings. The processes that are usually encountered in thermodynamic analysis of systems can be identified as any one or a combination of the following elementary processes:

- (i) Constant volume (isochoric) process
- (ii) Constant pressure (isobaric) process
- (iii) Constant temperature (isothermal) process.
- (iv) Adiabatic process.

3.5 Constant volume process

Suppose a gas enclosed in a rigid vessel is interacting with the surroundings and absorbs energy Q as heat.

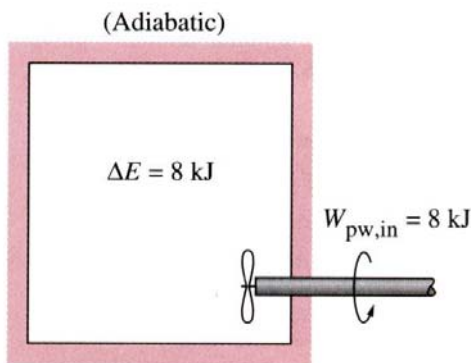

Since the vessel is rigid, the work done W due to expansion or compression is zero. Applying the first law, we get

$$dU = dQ \text{ or } Q = U_2 - U_1$$

That is, heat interaction is equal to the change in internal energy of the gas. If the system contains a mass m equal of an ideal gas, then

$$Q = \Delta U = mC_v (T_2 - T_1)$$

The path followed by the gas is shown on a P-V diagram. Now consider the fluid contained in a rigid vessel as shown. The vessel is rigid and insulated. Shaft work is done on the system by a paddle wheel.

Constant volume process involving electrical work:

$$-W_s = U_2 - U_1$$

Since the vessel is rigid, the PdV work is zero. Moreover, the vessel is insulated and hence $dQ = 0$. Application of the first law of thermodynamics gives

$$dU = dQ - dW = dQ - (dW_{pdv} + dW_s)$$

$$\text{or } dU = -dW_s \text{ or } -W_s = \Delta U = U_2 - U_1$$

Where dW_{pdv} is the compression /expansion work and dW_s is the shaft work. That is increase in internal energy of a system at a constant volume, which is enclosed by an adiabatic wall, is equal to the shaft work done on the system.

3.6 Constant pressure process

Several industrial processes are carried out at constant pressure. A few examples of constant pressure processes are: (a) reversible heating/cooling of a gas (b) phase change (c) paddle wheel work (d) electrical work. For a constant pressure process, the work done W is given by

$$W = \int PdV = P (V_2 - V_1)$$

Application of the first law of thermodynamics gives

$$dU = dQ - dW = dQ - PdV = dQ - d(PV)$$

$$\text{or } dQ = dU + d(PV) = d(U + PV) = dH$$

$$\text{or } Q = \Delta H$$

That is in a constant pressure process, the heat interaction is equal to the increase in the enthalpy of the system. Now consider the constant pressure processes in which the system is enclosed by an adiabatic boundary. Application of the first law gives:

$$dU = dQ - dW = dQ - (PdV + dW_s)$$

Here, the net work done (dW) consists of two parts – the PdV work associated with the motion of the boundary and ($-dW_s$), the shaft work (or electrical work) done by the surroundings. Since the system is enclosed by an adiabatic boundary, $dQ = 0$ the equation can be written as

$$-dW_s = dU + d(PV) = dH$$

That is, the increase in the enthalpy of the system is equal to the shaft work done on the system.

3.7 Constant temperature process

Suppose a gas enclosed in the piston cylinder assembly is allowed to expand from P_1 to P_2 while the temperature is held constant. Then application of the first law gives:

$$dU = dQ - dW = dQ - PdV$$

It is not possible to calculate work and heat interactions unless the relationships between the thermodynamic properties of the gas are known. Suppose the gas under consideration is an ideal gas (which follows the relation $Pv = RT$ and $u = u(T)$ only) then for an isothermal process,

$$dU = 0$$

$$dQ = PdV = RTdv/v \text{ or } Q = W = RT \ln(v_2/v_1)$$

3.8 Reversible adiabatic (Isentropic process)

Polytropic Process

$$W = \int cdv / v^n$$

$$w = (P_1 v_1 - P_2 v_2) / (n-1)$$

$$du = dq - dw$$

$$u_2 - u_1 = q - (P_1v_1 - P_2v_2)/(n-1)$$

$$u_2 - u_1 = C_v (T_2 - T_1) = q - w$$

$$q = R(T_2 - T_1)/(\gamma-1) + (P_1v_1 - P_2v_2)/(n-1)$$

$$= R (T_1 - T_2) \{1/(n-1) - 1/(\gamma-1)\}$$

$$= (P_1v_1 - P_2v_2)/(n-1) \{(\gamma - n)/(\gamma-1)\}$$

$$= w. \{ (\gamma - n)/(\gamma-1)\}$$

Example: Air (ideal gas with $\gamma = 1.4$) at 1 bar and 300K is compressed till the final volume is one-sixteenth of the original volume, following a polytropic process $Pv^{1.25} = \text{const}$. Calculate (a) the final pressure and temperature of the air, (b) the work done and (c) the energy transferred as heat per mole of the air.

Solution: (a) $P_1v_1^{1.25} = P_2v_2^{1.25}$

$$P_2 = P_1(v_1/v_2)^{1.25} = 1(16)^{1.25} = \mathbf{32 \text{ bar}}$$

$$T_2 = (T_1P_2v_2)/(P_1v_1) = (300 \times 32 \times 1)/(1 \times 16) \\ = \mathbf{600K}$$

(b) $w = (P_1v_1 - P_2v_2)/(n-1)$
 $= R_u(T_1 - T_2)/(n-1)$
 $= 8.314 (300 - 600)/(1.25-1) = \mathbf{-9.977 \text{ kJ/mol}}$

(c) $q = w. \{ (\gamma - n)/(\gamma-1)\}$
 $= -9.977 (1.4 - 1.25)/(1.4-1)$
 $= \mathbf{-3.742 \text{ kJ/mol}}$

3.9 Control-Volume Analysis

Control volume is a volume in space of special interest for particular analysis. The surface of the control volume is referred as a control surface and is a closed surface. The surface is defined with relative to a coordinate system that may be fixed, moving or rotating.

Mass, heat and work can cross the control surface and mass and properties can change with time within the control volume.

Examples: turbines, compressors, nozzle, diffuser, pumps, heat exchanger, reactors, a thrust-producing device, and combinations of these.

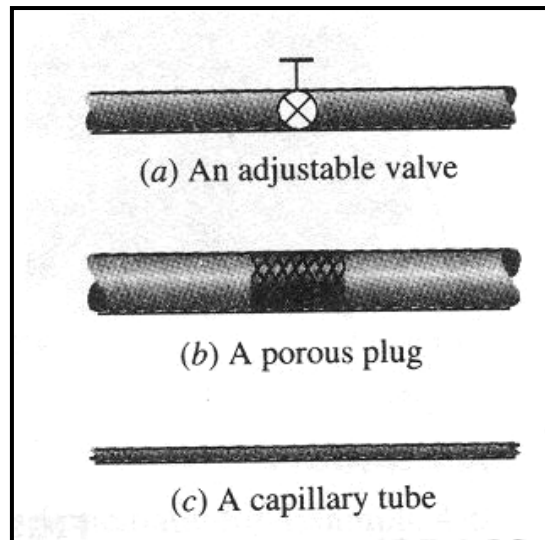
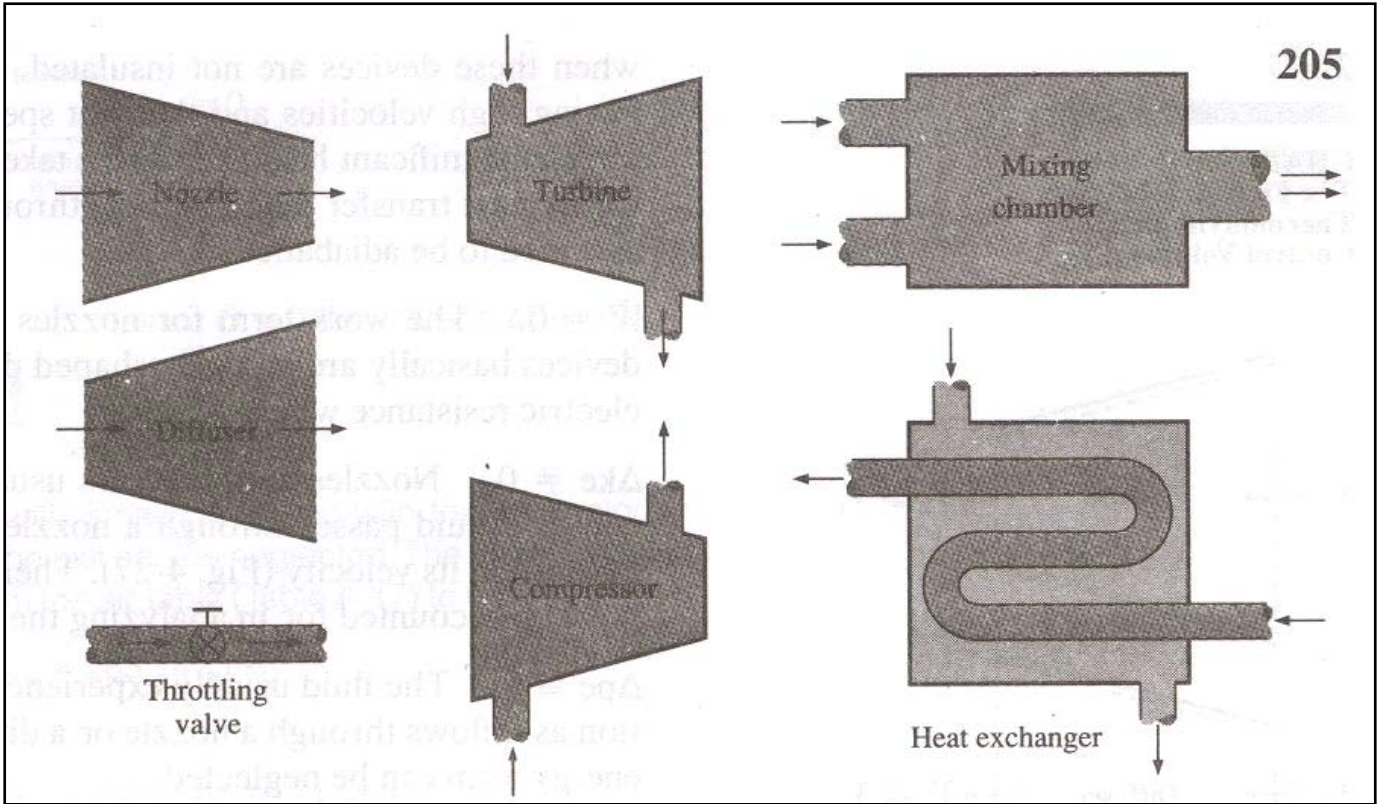

3.10 Steady state steady flow process

The first law of thermodynamics can be used to develop the so-called general energy equation for open systems. Imagine a heat engine taking in a working substance (WS) in an initial state characterized by the energies U_1 , KE_1 , and PE_1 .

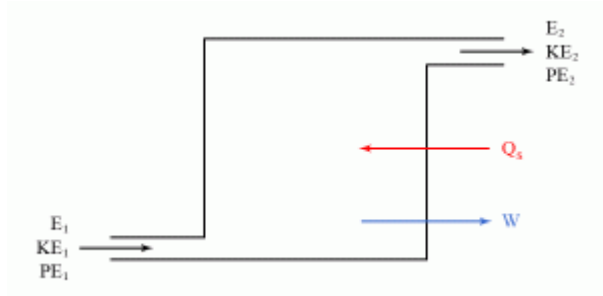

The WS passes through the machine having Q units of heat supplied to it and giving a work output of W units. The WS then leaves the machine with energies U_2 , KE_2 , and PE_2 .

The work done to drive one unit mass of air through the system is given by:

$$\text{Work done} = F_2 l_2 - F_1 l_1 \dots\dots\dots (1)$$

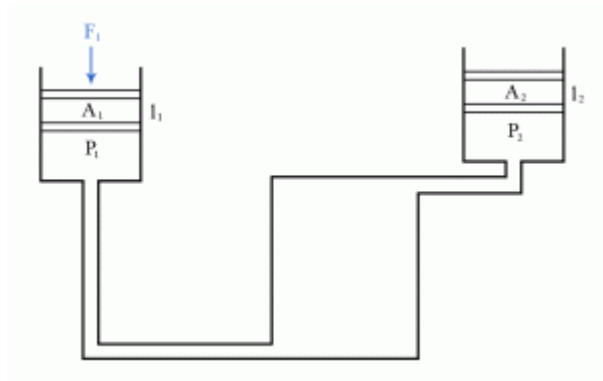

which can also be written, by taking into account that the force acting on a piston is $F = P \times A$, as:

$$\text{Work done} = P_2 A_2 l_2 - P_1 A_1 l_1 \dots\dots\dots (2)$$

Equation (2) can be written as:

$$\text{Work done} = P_2 V_2 - P_1 V_1 \dots\dots\dots (3)$$

where P is the pressure, and V the volume.

Applying the first law of thermodynamics, which states that the energy which enters the system equals that which leaves the system and taking equation (3) into account, we can write that:

$$U_1 + KE_1 + PE_1 + Q = U_2 + KE_2 + PE_2 + W + (P_2 V_2 - P_1 V_1) \dots\dots\dots (4)$$

Equation (4) can also be written as:

$$(U_1 + P_1V_1) + KE_1 + PE_1 + Q = (U_2 + P_2V_2) + KE_2 + PE_2 + W \dots\dots\dots(5)$$

and is called the general energy equation.

The term $(U + PV)$ is called enthalpy and is denoted with H . Thus, the general energy equation can also be written as:

$$H_1 + KE_1 + PE_1 + Q = H_2 + KE_2 + PE_2 + W \dots\dots\dots (6)$$

where H_1 is the enthalpy characterizing the first state, while H_2 is the enthalpy characterizing the second state.

The form of the general energy equation can also be adapted to particular applications. For example, for a petrol engine, the KE and PE terms are negligible, and thus equation (6) becomes:

$$H_1 + Q = H_2 + W \dots\dots\dots (7)$$

from which we have that:

$$Q = W + (H_2 - H_1) \dots\dots\dots (8)$$

Therefore, in this case, the heat supplied to the WS equals the work done by the WS plus the gain in enthalpy.

For a gas turbine, we can ignore only the PE terms, and thus equation (6) becomes:

$$H_1 + KE_1 + Q = H_2 + KE_2 + W \dots\dots\dots (9)$$

from which:

$$Q = W + (KE_2 - KE_1) + (H_2 - H_1) \dots\dots\dots (10)$$

Therefore, in this case, the heat supplied to the WS equals the work done by the WS plus the gain in kinetic energy plus the gain in enthalpy.

For a non-flow process, there are no PV, KE, or PE terms. Thus, in this case, equation (5) becomes:

$$U_1 + Q = U_2 + W \dots\dots\dots (11)$$

from which:

$$Q = W + (U_2 - U_1) \dots\dots\dots (12)$$

Hence, the heat supplied to the WS equals the work done by the WS plus the gain in internal energy.

We can further apply the general energy equation to more comprehensive particular cases.

1) Constant Volume Processes

In this case, the work output is zero, and the processes are invariably non-flow.



Nearly all the terms in the general energy equation (5) are eliminated, leaving:

$$U_1 + Q = U_2 \dots\dots\dots (13)$$

or:

$$Q = U_2 - U_1 \dots\dots\dots (14)$$

Therefore, for constant volume processes, all the heat supplied goes into increasing the internal energy of the WS.

2) Constant Pressure Processes

a) Non-Flow Processes

Consider that the WS experiences an isobaric change in volume as shown the in Figure:

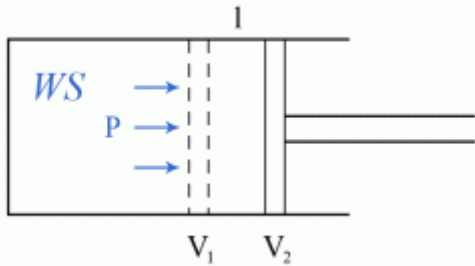

As the force acting on the piston is given by:

$$F = P \times A \dots\dots\dots (15)$$

the work done:

$$W = F \times l \dots\dots\dots (16)$$

becomes:

$$W = P \times A \times l \dots\dots\dots (17)$$

or, furthermore:

$$W = P (V_2 - V_1) \dots\dots\dots (18)$$

In the general energy equation (5) most terms are eliminated, leaving:

$$U_1 + Q = U_2 + W \dots\dots\dots (19)$$

which leads to:

$$Q = (U_2 - U_1) + W \dots\dots\dots (20)$$

Combining equations (18) and (19):

$$Q = (U_2 - U_1) + P (V_2 - V_1) \dots\dots\dots (21)$$

or, furthermore:

$$Q = (U_2 + P_2V_2) - (U_1 + P_1V_1) \dots\dots\dots (22)$$

Thus:

$$Q = H_2 - H_1 \dots\dots\dots (23)$$

Therefore, for constant pressure non-flow processes, the heat supplied to the WS equals the gain in enthalpy.

b) Flow Processes

In this case, considering that all the changes to the kinetic and potential energies are negligible, the general energy equation (6) becomes:

$$H_1 + Q = H_2 + W \dots\dots\dots (24)$$

which leads to:

$$Q = W + (H_2 - H_1) \dots\dots\dots (25)$$

However, it is impossible to devise a machine that operates a constant pressure flow process giving a constant work output. Therefore, in all practical cases, the heat supplied to the WS equals the gain in enthalpy.

3) Adiabatic Processes

These are processes during which there is no heat transfer between the WS and the surroundings.

a) Non-Flow Processes

For adiabatic non-flow processes, the general energy equation (5) becomes:

$$U_1 = U_2 + W \dots\dots\dots (26)$$

Therefore, the work done is:

$$W = U_1 - U_2 \dots\dots\dots (27)$$

and it thus equivalates the loss of internal energy.

b) Flow Processes

This category includes all rotary turbines and compressors. The general energy equation (6) can be written in this case as:

$$H_1 = H_2 + W \dots\dots\dots (28)$$

from which the work done becomes:

$$W = H_1 - H_2 \dots\dots\dots (29)$$

and it thus equivalates the loss of enthalpy.

4) Throttling Processes

Consider two points, **1** and **2**, which are far enough from the orifice so that the **KE** terms are negligible (see Figure).

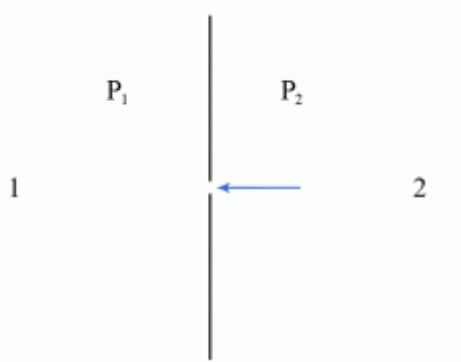

Furthermore, consider that there is no heat supplied and there is no work output. Therefore, the general energy equation (6) becomes in this case:

$$H_1 = H_2 \dots\dots\dots (30)$$

Hence, for throttling processes, there is no change in enthalpy.

3.11 Turbine

A turbine is a rotary steady state steady flow machine whose purpose is the production of shaft power at the expense of the pressure of the working fluid.

Two general classes of turbines are steam and gas turbines depending on the working substance used.

Usually, changes in potential energy are negligible, as is the inlet kinetic energy. Often the exit kinetic energy is neglected (**if in a problem, the flow velocities are specified, the kinetic energy term should be included**).

Normally, the process in the turbine is adiabatic and the work output reduces to decrease in enthalpy from the inlet to exit states.

$$\dot{W}_{sh} = \dot{m}(h_i - h_e)$$

3.12 Compressor / pump

The purpose of a compressor (gas) or pump (liquid) is the same, to increase the pressure of a fluid by putting in shaft work (power). There are two fundamentally different types of compressors:

1. The rotary type (either axial or centrifugal flow)
2. A piston/cylinder type compressor.

The first type is analyzed using control volume approach (steady state steady flow process). The working fluid enters the compressor at low pressure and exits at high pressure.

Usually, changes in potential energy are negligible as is the inlet kinetic energy. Often, exit kinetic energy is neglected as well (**wherever, in a problem, velocities are specified, ke term should not be neglected**).

The compression process is usually adiabatic.

$$\dot{W}_{sh} = \dot{m}[(h_i - h_e) + (V_i^2 - V_e^2) / 2]$$

3.13 Nozzle

A nozzle is a steady state steady flow device to create a high velocity fluid stream at the expense of its pressure. It is contoured in an appropriate manner to expand the fluid to a lower pressure.

Since the objective of the device is to increase the flow velocity, hence kinetic energy, the kinetic energy term cannot be ignored. Usually, the process through the nozzle is treated as adiabatic.

Since there are no moving parts, shaft work is zero. The potential energy term (for gases) is negligible and hence omitted.

$$(h_i - h_e) = (V_e^2 - V_i^2) / 2$$

3.14 Diffuser

A steady state steady flow device meant to decelerate high velocity fluid resulting in increased pressure of the fluid. It is the opposite of a nozzle as far as the purpose is concerned. The assumptions are similar to those for a nozzle.

3.15 A systematic approach to problem solving

Step 1. Identify the system and draw a sketch of it. The system that is about to be analyzed should be identified on the sketch by drawing its boundaries using the dashed lines.

Step 2. List the given information on the sketch. Heat and work interactions if any should also be indicated on the sketch with proper directions.

Step 3. State any assumptions:

The simplifying assumptions that are made to solve a problem should be stated and fully justified.

Commonly made assumptions:

- (i) Assuming process to be quasi-equilibrium
- (ii) Neglecting PE and KE
- (iii) Treating gas as ideal
- (iv) Neglecting heat transfer from insulated systems.

Step 5. Apply the conservation equations.

Step 6. Draw a process diagram.

Determine the required properties and unknowns.

Example 1: A 0.1 m^3 rigid tank contains steam initially at 500 kPa and 200°C . The steam is now allowed to cool until the temperature drops to 50°C . Determine the amount of heat transfer during this process and the final pressure in the tank.

State 1: $P_1 = 500 \text{ kPa}$, $T_1 = 200^\circ\text{C}$

$$v_1 = 0.4249 \text{ m}^3/\text{kg}, u_1 = 2642.9 \text{ kJ/kg}$$

State 2: $v_2 = v_1 = 0.4269 \text{ m}^3/\text{kg}$

$$T_2 = 50^\circ\text{C} \rightarrow v_f = 0.001 \text{ m}^3/\text{kg}$$

$$v_g = 12.03 \text{ m}^3/\text{kg}$$

$$u_f = 209.32 \text{ kJ/kg}$$

$$u_g = 2443.5 \text{ kJ/kg}$$

$$P_2 = P_{sat} @ 50^\circ\text{C} = \underline{\underline{12.349 \text{ kPa}}}$$

$$v_2 = v_f + x_2 v_{fg}$$

$$0.4249 = 0.001 + x_2(12.03 - 0.001)$$

$$x_2 = 0.0352$$

$$\begin{aligned}u_2 &= u_f + x_2 u_g \\ &= 209.32 + (0.0352)(2443.5 - 209.32) \\ &= 288.0 \text{ kJ/kg}\end{aligned}$$

$$\begin{aligned}m &= V/u = (0.1 \text{ m}^3/\text{kg}) / (0.4249 \text{ m}^3/\text{kg}) \\ &= 0.235 \text{ kg}\end{aligned}$$

$$\begin{aligned}-Q_{out} &= \Delta U = m(u_2 - u_1) \\ Q_{out} &= m(u_1 - u_2) \\ &= (0.235)(2642.9 - 288) \\ &= \underline{\underline{553.4 \text{ kg}}}\end{aligned}$$

Example 2: A piston/cylinder contains 50 kg of water at 200 kPa with a volume of 0.1 m^3 . Stop in the cylinder is placed to restrict the enclosed volume to 0.5 m^3 . The water is now heated until the piston reaches the stops. Find the necessary heat transfer.

At 200 kPa,

$$\begin{aligned}v_f &= 0.001061 \text{ m}^3/\text{kg} \\ v_{fg} &= 0.88467 \text{ m}^3/\text{kg} \\ h_f &= 504.68 \text{ kJ/kg} \\ h_{fg} &= 2201.96 \text{ kJ/kg}\end{aligned}$$

This is a constant pressure process. Hence,
 $Q = \Delta H$

The specific volume initially,

$$\begin{aligned}v_i &= 0.1 / 50 = 0.002 \text{ m}^3/\text{kg} \\ v &= v_f + x v_{fg} \\ &= 0.001061 + x (0.88467)\end{aligned}$$

Therefore, $x = (0.002 - 0.001061) / 0.88467$
 $= 0.001061$

$$\begin{aligned}h &= h_f + x h_{fg} \\ &= 504.68 + 0.001061(2201.96) \\ &= 507.017 \text{ kJ/kg}\end{aligned}$$

$$v_{final} = 0.5 / 50 = 0.01 \text{ m}^3/\text{kg}$$

$$v = v_f + x v_{fg}$$

Therefore, $x = (0.01 - 0.001061) / 0.88467$
 $= 0.01$

$$h_{final} = 504.68 + 0.01(2201.96)$$

$$= 526.69 \text{ kJ/kg}$$

$$Q = \Delta H = 50 (526.69 - 507.017) \\ = \underline{\underline{983.65 \text{ kJ/kg}}}$$

Example 3: A rigid insulated tank is separated into two rooms by a stiff plate. Room A of 0.5 m^3 contains air at 250 kPa, 300 K and room B of 1 m^3 has air at 150 kPa, 1000 K. The plate is removed and the air comes to a uniform state without any heat transfer. Find the final pressure and temperature.

The system comprises of room A and B together. This is a constant internal energy process as there is no heat and work exchange with the surroundings.

$$m_A = P_A V_A / RT_A \\ = (250 \times 1000 \times 0.5) / (287 \times 300) \\ = 1.452 \text{ kg}$$

$$m_B = P_B V_B / RT_B \\ = (150 \times 1000 \times 1.0) / (287 \times 1000) \\ = 0.523 \text{ kg}$$

$$\Delta U_A + \Delta U_B = 0$$

Let T_f be the final temperature at equilibrium

$$m_A (T_f - 300) + m_B (T_f - 1000) = 0$$

$$1.452 (T_f - 300) + 0.523 (T_f - 1000) = 0$$

$$T_f = \underline{\underline{485.37 \text{ K}}}$$

$$P_f = (1.452 + 0.523) \times 287 \times 485.37 / 1.5 \\ = \underline{\underline{183.41 \text{ kPa}}}$$

Example 4: A piston / cylinder assembly contains 0.1 m^3 of superheated steam at 10 bar and 400°C . If the steam is allowed to expand reversibly and adiabatically to a pressure of 3 bar, calculate the work done by the steam.

At 10 bar and 400°C ,

$$v = 0.3065 \text{ m}^3/\text{kg}$$

$$h = 3264.4 \text{ kJ/kg}$$

$$s = 7.4665 \text{ kJ/kg K}$$

At 3 bar,

$$s_g = 6.9909 \text{ kJ/kg K}$$

This is an isentropic process as initial entropy value is greater than s_g at 3 bar, the steam is superheated at the end of the process.

At 3 bar and 200°C,

$s = 7.3119 \text{ kJ/kg K}$ and

at 300°C, $s = 7.7034 \text{ kJ/kg K}$

therefore, the final state is having a temperature between 200°C and 300°C.

Equating $s_i = s_{\text{final}}$,

Find the enthalpy and specific volume by interpolation. Then calculate u_i and u_{final} .

The work done = $\Delta U = m(u_i - u_{\text{final}})$

Example 1 (Nozzle)

Nitrogen gas flows into a convergent nozzle at 200 kPa, 400 K and very low velocity. It flows out of the nozzle at 100 kPa, 330 K. If the nozzle is insulated, find the exit velocity.

$V_i = 0$

Adiabatic nozzle

The SSSF equation:

$$\begin{aligned} V_e^2/2 &= (h_i - h_e) = C_p(T_i - T_e) \\ &= \{\gamma R_u/M(\gamma-1)\} (T_i - T_e) \\ &= \{1.4 * 8314/(28*0.4)\} (400-330) \\ &= 72747.5 \text{ m}^2/\text{s}^2 \end{aligned}$$

We get, $V_e = 381.44 \text{ m/s}$

Example 2 (Diffuser)

Air at 10° C and 80 kPa enters the diffuser of a jet engine steadily with a velocity of 200 m/s. The inlet area of the diffuser is 0.4 m². The air leaves the diffuser with a velocity that is very small compared with the inlet velocity. Determine (a) the mass flow rate of the air and (b) the temperature of the air leaving the diffuser.

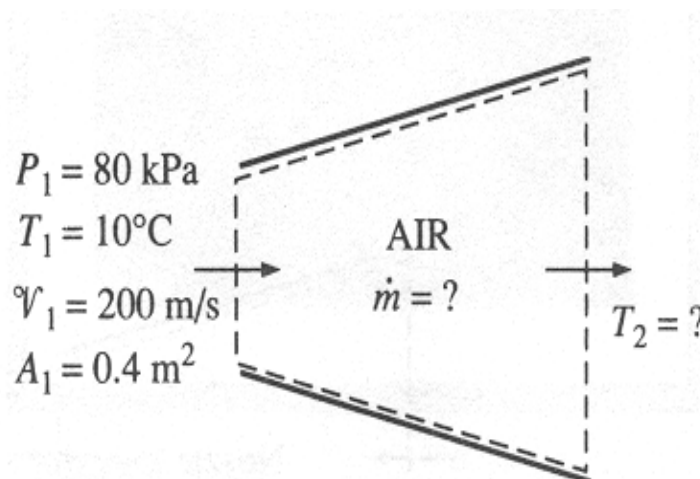

Solution:

Assumptions: This is a steady flow process. Air is an ideal gas. The potential energy change is zero. Kinetic energy at diffuser exit is negligible. There are no work interactions. Heat transfer is negligible.

To determine the mass flow rate, we need the specific volume of air.

$$v_1 = RT_1/P_1 = 0.287 * 283 / 80 = 1.015 \text{ m}^3/\text{kg}$$

$$m = 1/v_1(V_1A_1) = (200 * 0.4) / 1.015 = 78.8 \text{ kg/s}$$

For steady flow, mass flow through the diffuser is constant.

$$(b) (h_1 + V_1^2/2) = (h_2 + V_2^2/2) \quad (\text{since } Q = 0, W = 0, \text{ and } \Delta PE = 0)$$

$$h_2 = h_1 - (V_2^2 - V_1^2)/2$$

The exit velocity of a diffuser is very small and therefore neglected.

$$h_2 = h_1 + V_1^2/2$$

$$T_2 = T_1 + V_1^2/2C_p$$

$$T_2 = 283 + 200^2/(2*1004) \\ = 302.92 \text{ K}$$

3.16 Compressing air by a compressor

Air at 100 kPa and 280 K is compressed steadily to 600 kPa and 400 K. The mass flow rate of air is 0.02 kg/s and a heat loss of 16 kJ/kg occurs during the process. Assuming the changes in KE and

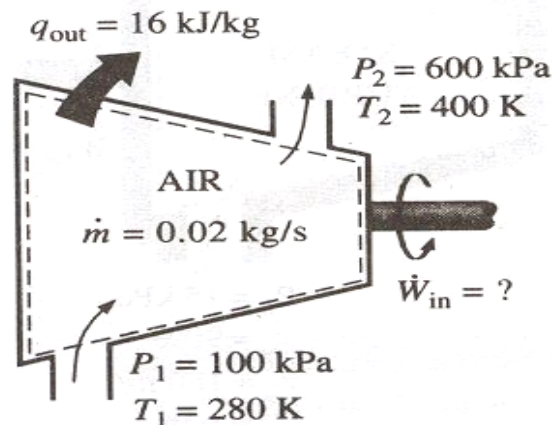

PE are negligible, determine the necessary power input to the compressor.

We take the compressor as the system. This is a control volume since the mass crosses the system boundary during the process. Heat is lost from the system and work is supplied to the system.

With similar assumptions as in the diffuser problem,

$$w = q + (h_2 - h_1)$$

$$\begin{aligned} \text{The input power} &= m (q + (h_2 - h_1)) \\ &= 0.02 (16 + (1.004*(400 - 280))) = \mathbf{2.73 \text{ kW}} \end{aligned}$$

3.17 Power generation by a steam turbine

The power output of an adiabatic steam turbine is 5 MW, and the inlet and exit conditions of the steam are as indicated in the figure.

- Compare the magnitude of Δh , ΔKE , and ΔPE
- Determine the work done per unit mass of the steam flowing through the turbine
- Calculate the mass flow rate of the steam.

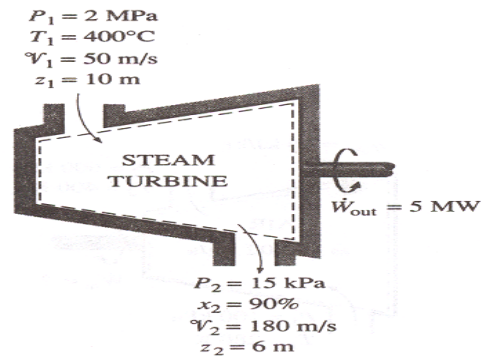

We take the turbine as a system. The control volume is shown in the figure. The system, the inlet and exit velocities do work and elevations are given and thus the kinetic and potential energies are to be considered.

At the inlet, the steam is in superheated vapor state.

$$h_1 = 3247.6 \text{ kJ/kg.}$$

At the turbine exit, we have a saturated liquid-vapor mixture at 15 kPa pressure. The enthalpy at this state is

$$\begin{aligned} h_2 &= h_f + x_2 h_{fg} \\ &= 225.94 + 0.9 * 2373.1 \\ &= 2361.73 \text{ kJ/kg} \end{aligned}$$

$$\begin{aligned} \Delta h &= h_2 - h_1 \\ &= 2361.73 - 3247.6 = \mathbf{-885.87 \text{ kJ/kg}} \end{aligned}$$

$$\begin{aligned}\Delta ke &= (V_2^2 - V_1^2)/2 = (180^2 - 50^2)/2 * 1000 \\ &= \mathbf{14.95 \text{ kJ/kg}}\end{aligned}$$

$$\begin{aligned}\Delta Pe &= g(Z_2 - Z_1) = 9.807 * (6 - 10)/1000 \\ &= \mathbf{-0.04 \text{ kJ/kg}}\end{aligned}$$

$$\begin{aligned}w_{out} &= -[(h_2 - h_1) + (V_2^2 - V_1^2)/2 + g(Z_2 - Z_1)] \\ &= -[-885.87 + 14.95 - 0.04] \\ &= \mathbf{870.96 \text{ kJ/kg}}\end{aligned}$$

d) The required mass flow rate for a 5MW power output is $5000/870.96 = \mathbf{5.74 \text{ kg/s}}$

3.18 Heat exchangers

Heat exchangers are devices where two moving fluid streams exchange heat without mixing.

Heat is transferred from the hot fluid to the cold one.

Under steady operation, the mass flow rate of each fluid stream flowing through a heat exchanger remains constant.

$$w = 0, \Delta ke = 0, \Delta pe = 0$$

Heat exchangers are intended for heat transfer between two fluids within the device.

Usually, the entire heat exchanger is selected as the control volume and Q becomes zero.

3.19 Throttle

Throttle is any kind of flow restricting device that causes a significant pressure drop in the fluid.

The pressure drop does not involve any work.

A large drop in temperature often accompanies the pressure drop in the fluid.

Throttling devices are commonly used in refrigeration and air-conditioning applications.

$$q = 0, w = 0, \Delta ke = 0, \Delta pe = 0$$

Hence across a steady flow throttling device,

$$h_2 = h_1$$

Internal energy + flow energy = constant

3.20 Thermal Reservoir

A thermal reservoir is a large system (very high mass x specific heat value) from which a quantity of energy can be absorbed or added as heat without changing its temperature. The atmosphere and sea are examples of thermal reservoirs.

Any physical body whose thermal energy capacity is large relative to the amount of energy it supplies or absorbs can be modeled as a thermal reservoir.

A reservoir that supplies energy in the form of heat is called a source and one that absorbs energy in the form of heat is called a sink.

3.21 Heat Engine

It is a cyclically operating device which absorbs energy as heat from a high temperature reservoir, converts part of the energy into work and rejects the rest of the energy as heat to a thermal reservoir at low temperature.

The working fluid is a substance, which absorbs energy as heat from a source, and rejects energy as heat to a sink.

3.21.1 Thermal Power Plant

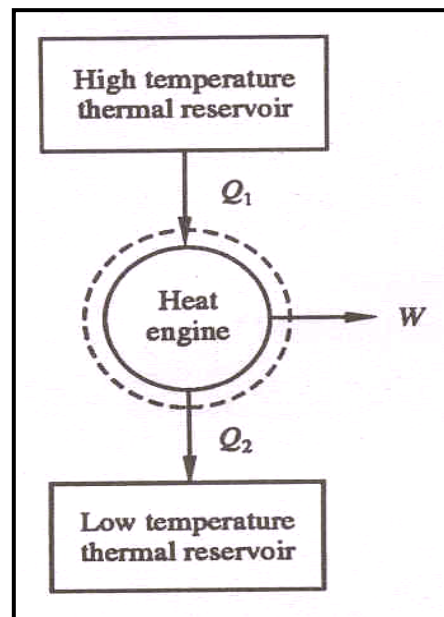
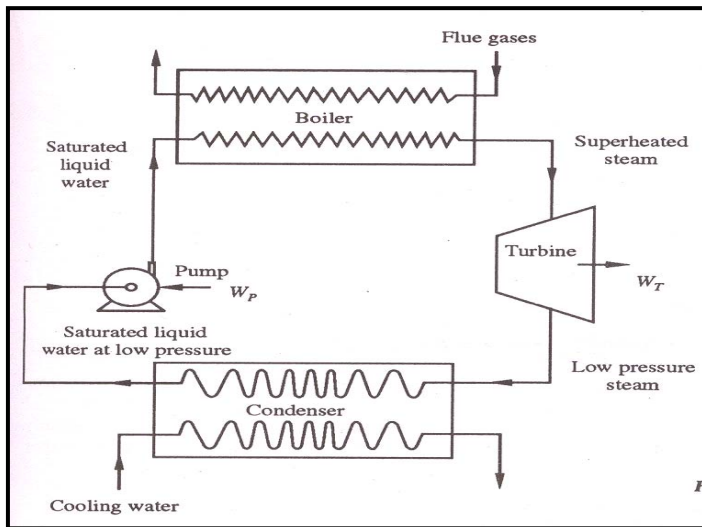

Schematic representation of Heat Engine

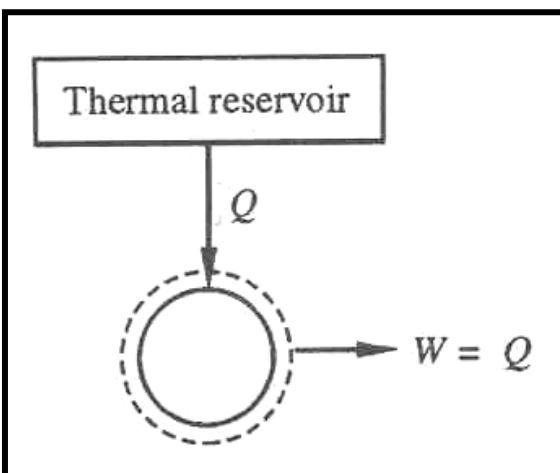

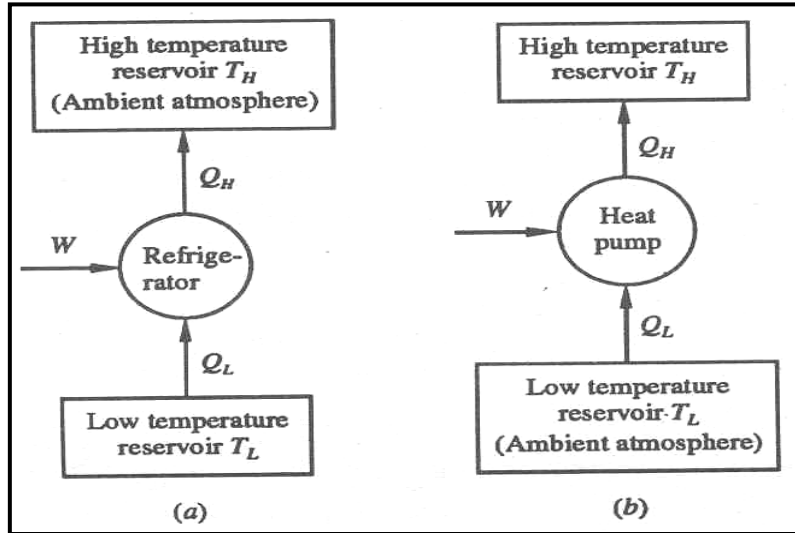

Schematic representation of Refrigerator and Heat pump.

Working Fluid ----- Water

Q₁ – Heat received from hot gases

W_T – Shaft work by turbine

Q₂ – Heat rejected to cooling water in condenser

W_P – Work done on the pump

$$W_{net} = W_T - W_P$$

$$W = Q_1 - Q_2$$

Thermal Efficiency,

$$\eta = \frac{W_{net}}{Q_1} = \frac{W}{Q_1} = \frac{Q_1 - Q_2}{Q_1}$$

Q_L – Heat absorbed from low temperature thermal reservoir

Q_H – Heat rejected to a high temperature thermal reservoir when work (W) is done on it.

$$(COP)_R = \frac{Q_L}{W} = \frac{Q_L}{Q_H - Q_L}$$

$$(COP)_{HP} = \frac{Q_H}{W} = \frac{Q_H}{Q_H - Q_L}$$

In a reversible, isothermal expansion of an ideal gas, all the energy absorbed as heat by the system is converted completely into work. However this cannot produce work continuously (not a cycle).

Single reservoir heat engine (1 T engine) is not possible.

4.0 SECOND LAW OF THERMODYNAMICS

Engineering thermodynamics is based on two main principles namely the First and Second Laws of Thermodynamics.

4.0.1 Kelvin-Planck Statement: - It is impossible to devise a cyclically operating device, which produces no other effect than the extraction of heat from a single thermal reservoir and delivers an equivalent amount of work.

Heat engine with single thermal reservoir is not possible.

For a 1-T engine the thermal efficiency $\eta=W/Q=1$. No heat engine can have efficiency equal to unity.

Clausius Statement: - It is impossible to construct a device that operates in a cycle and produces no effect other than the transfer of heat from a lower-temperature body to higher-temperature body.

Equivalence of the two statements

To prove that violation of the Kelvin-Planck Statement leads to a violation of the Clausius Statement, let us assume that Kelvin-Planck statement is incorrect.

Consider a cyclically working device 1, which absorbs energy Q_1 as heat from a thermal reservoir at T_H . Equivalent amount of work $W(W=Q_1)$ is performed.

Consider another device 2 operating as a cycle, which absorbs energy Q_L as heat from a low temperature thermal reservoir at T_L and rejects energy Q_H ($Q_H=Q_L+W$). Such a device does not violate Clausius statement.

If the two devices are now combined, the combined device (enclosed by the dotted boundary) transfers heat Q_L from the low temperature reservoir at T_L to a high temperature reservoir at T_H with out receiving any aid from an external agent, which is the violation of the Clausius statement.

Likewise let us assume that the Clausius statement is incorrect. So we have a device 1, cyclically working transferring heat Q from a low temperature reservoir at T_L to a high temperature thermal reservoir at T_H . Consider another device 2, which absorbs heat Q_1 from a high temperature reservoir at T_H does work W and rejects energy Q as heat tot the low temperature reservoir at T_L as shown in figure. If the two devices are combined (shown in figure by a dotted enclosure), then the combined device receives energy (Q_1-Q) as heat from a thermal reservoir and delivers equivalent work $(W=Q_1-Q)$ in violation of the Kelvin-Planck statement.

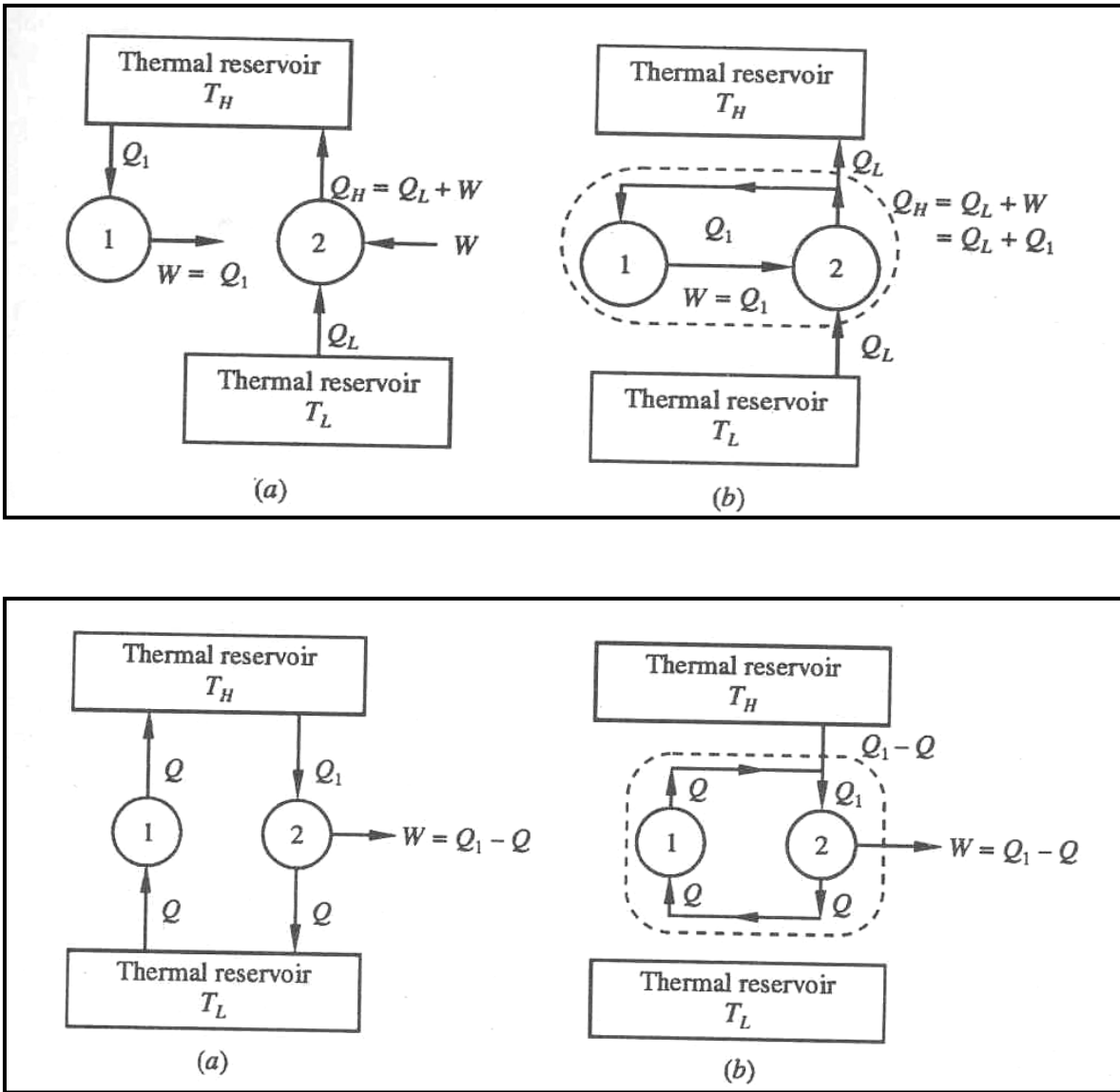

Therefore violation of Clausius statement leads to the violation of the Kelvin-Planck statement. Hence, these two statements are equivalent.

Perpetual Motion Machines

A device that violates the First law of thermodynamics (by creating energy) is called a Perpetual Motion Machine of the first kind.

A device that violates the Second law of thermodynamics is called a Perpetual Motion Machine of the Second kind.

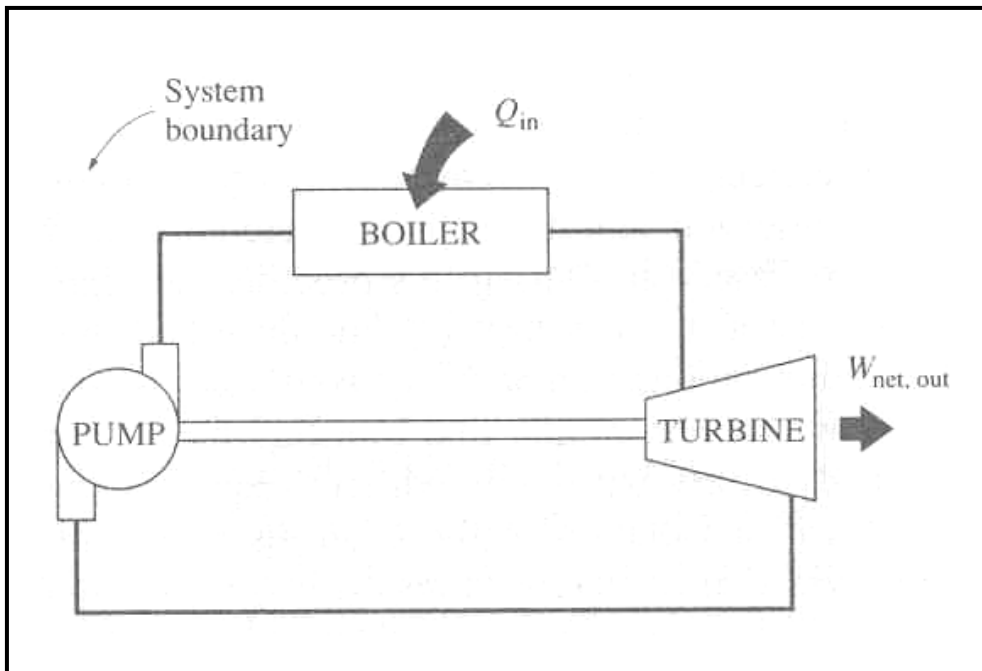
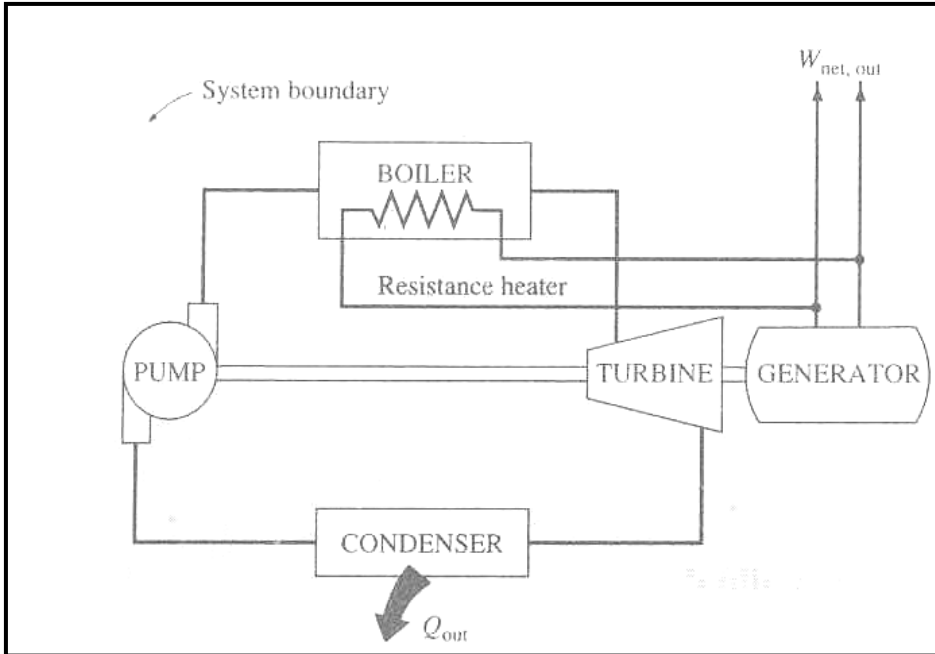

The first device supplies continuously energy with out receiving it. So this is a system creating energy and therefore violating the first law.

The second device exchanges heat with a single reservoir and thus a net amount of work. This need not violate the first law, but violates the second law and therefore will not work.

4.2 Reversible and Irreversible Processes

A process is said to be reversible if both the system and the surroundings can be restored to their respective initial states, by reversing the direction of the process. A reversible process is a process that can be reversed without leaving a trace on the surroundings. Processes that are not reversible are called Irreversible processes.

Irreversibilities

The factors that cause a process to be irreversible are called irreversibilities. Examples:

1. Friction
2. Unrestrained expansion
3. Mixing of two gases
4. Heat transfer across a finite temperature difference
5. Spontaneous chemical reactions
6. Expansion or Compression with finite pressure difference
7. Mixing of matter at different states

4.3 Carnot Cycle

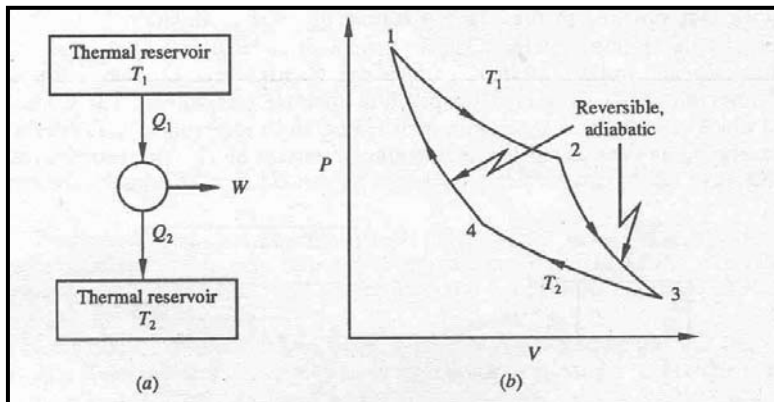

The Carnot cycle uses only two thermal reservoirs – one at high temperature T_1 and the other at two temperature T_2 .

If the process undergone by the working fluid during the cycle is to be reversible, the heat transfer must take place with no temperature difference, i.e. it should be isothermal.

The Carnot cycle consists of a reversible isothermal expansion from state 1 to 2, reversible adiabatic expansion from state 2 to 3, a reversible isothermal compression from state 3 to 4 followed by a reversible adiabatic compression to state 1.

The thermal efficiency, η is given by

$$\eta = \text{Net work done} / \text{Energy absorbed as heat}$$

During processes 2-3 and 4-1, there is no heat interaction as they are adiabatic.

$$Q_{1-2} = \int_1^2 P dv = \int_1^2 RT_1 \frac{dv}{v} = RT_1 \ln(v_2 / v_1)$$

Similarly for the process 3-4,

$$Q_{3-4} = \int_3^4 P dv = \int_3^4 RT_2 \frac{dv}{v} = RT_2 \ln(v_4 / v_3)$$

Net heat interaction = Net work done

$$= RT_1 \ln(v_2/v_1) + RT_2 \ln(v_4/v_3)$$

$$= RT_1 \ln(v_2/v_1) - RT_2 \ln(v_3/v_4)$$

The processes 2-3 and 4-1 are reversible, adiabatic and hence

$$T_1 v_2^{\gamma-1} = T_2 v_3^{\gamma-1}$$

$$\text{Or, } v_2/v_3 = (T_2/T_1)^{1/(\gamma-1)}$$

$$\text{And } T_2 v_4^{\gamma-1} = T_1 v_1^{\gamma-1}$$

$$\text{Or, } v_1/v_4 = (T_2/T_1)^{1/(\gamma-1)}$$

$$v_2/v_3 = v_1/v_4 \text{ or } v_2/v_1 = v_3/v_4$$

$$\eta = \{RT_1 \ln(v_2/v_1) - RT_2 \ln(v_3/v_4)\} / RT_1 \ln(v_2/v_1)$$

$$\begin{aligned} \eta &= (T_1 - T_2)/T_1 \\ &= 1 - T_2/T_1 \end{aligned}$$

4.3.1 The Carnot Principles

1. The efficiency of an irreversible heat engine is always less than the efficiency of a reversible one operating between same two thermal reservoirs.
2. The efficiencies of all reversible heat engines operating between the same two thermal reservoirs are the same.

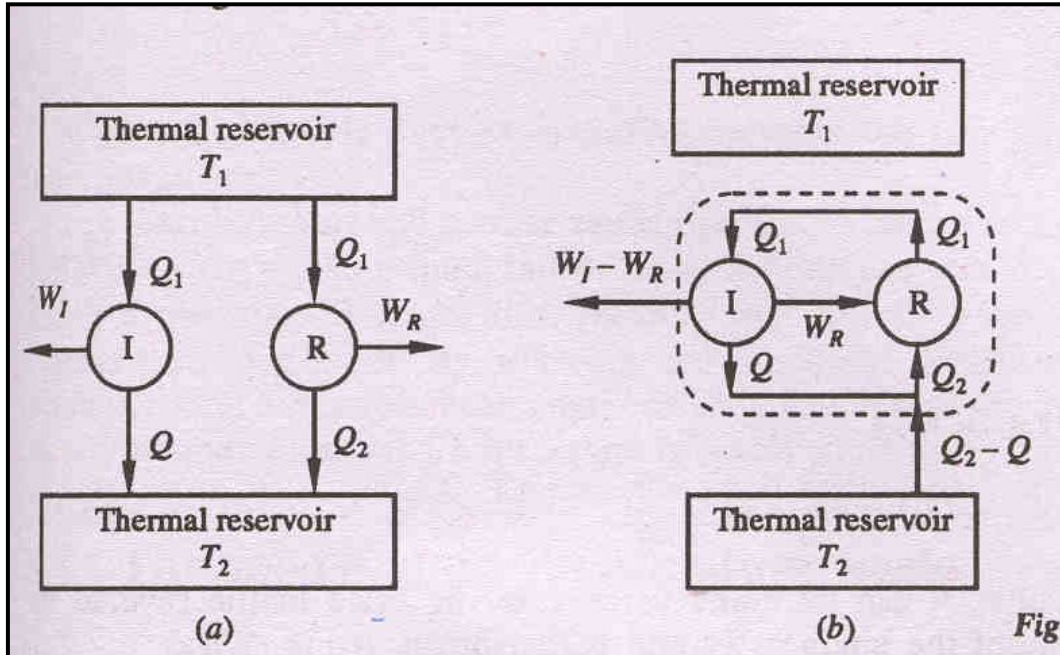

Fig.

Lets us assume it is possible for an engine I to have an efficiency greater than the efficiency of a reversible heat engine R.

$$\eta_I > \eta_R$$

Let both the engines absorb same quantity of energy Q_1 . Let Q and Q_2 represent the energy rejected as heat by the engines R, and I respectively.

$$W_I = Q_1 - Q$$

$$W_R = Q_1 - Q_2$$

$$\eta_I = W_I / Q_1 = (Q_1 - Q) / Q_1 = 1 - Q / Q_1$$

$$\eta_R = W_R / Q_1 = (Q_1 - Q_2) / Q_1 = 1 - Q_2 / Q_1$$

Since $\eta_I > \eta_R$,

$$1 - Q / Q_1 > 1 - Q_2 / Q_1$$

$$\text{or, } Q < Q_2$$

Therefore, $W_I (= Q_1 - Q) > W_R (= Q_1 - Q_2)$

Since the engine R is reversible, it can be made to execute in the reverse order. Then, it will absorb energy Q_2 from the reservoir at T_2 and reject energy Q_1 to the reservoir at T_1 when work W_R is done on it.

If now engines I and R are combined, the net work delivered by the combined device is given by

$$W_I - W_R = Q_1 - Q - (Q_1 - Q_2) = Q_2 - Q$$

The combined device absorbs energy $(Q_2 - Q)$ as heat from a single thermal reservoir and delivers an equivalent amount of work, which violates the second law of thermodynamics.

Hence, $\eta_R \geq \eta_I$

4.3.1.1 Carnot principle 2

Consider two reversible heat engines R_1 and R_2 , operating between the two given thermal reservoirs at temperatures T_1 and T_2 .

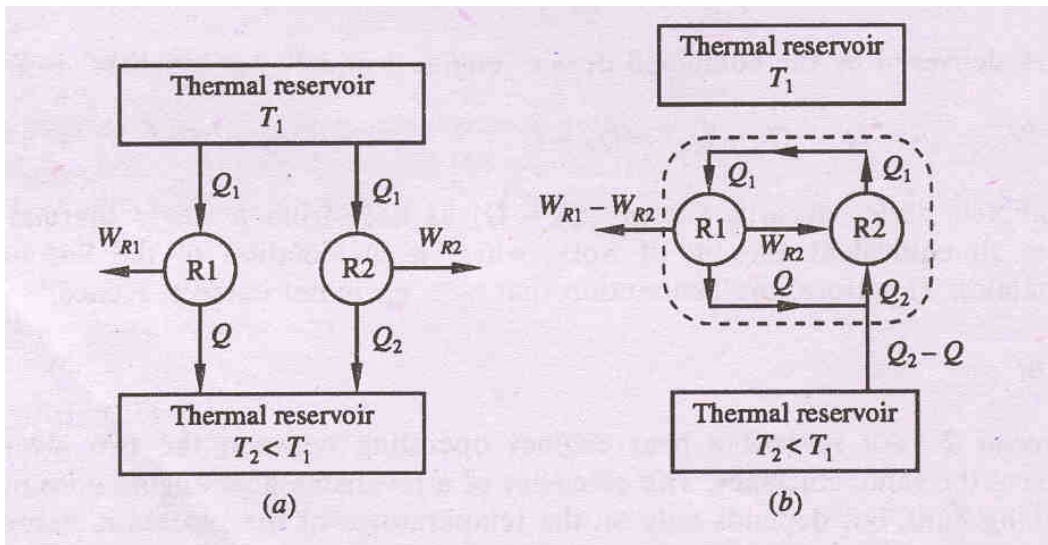

Let $\eta_{R1} > \eta_{R2}$

Q_1 = energy absorbed as heat from the reservoir at T_1 by the engines R_1 and R_2 , separately.

Q = energy rejected by reversible engine R_1 to the reservoir at T_2

Q_2 = energy rejected by reversible engine R_2 to the reservoir at T_2 .

$W_{R1} = Q_1 - Q =$ work done by a reversible engine R_1 .

$W_{R2} = Q_1 - Q_2 =$ work done by a reversible engine R_2

According to assumption,

$$\eta_{R1} > \eta_{R2}$$

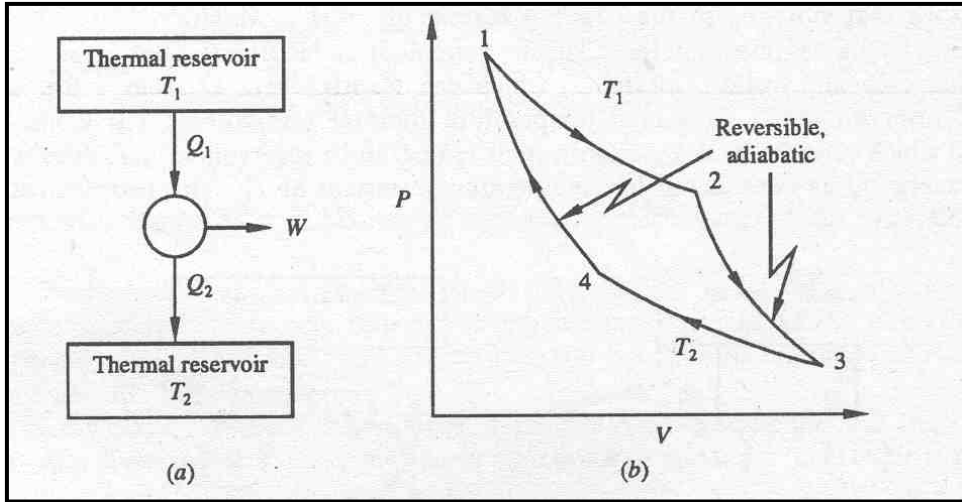

$$\text{Or, } 1 - Q/Q_1 > 1 - Q_2/Q_1$$

$$Q_1 - Q > Q_1 - Q_2 \text{ or } W_{R1} > W_{R2}$$

$$W_{R1} - W_{R2} = (Q_1 - Q) - (Q_1 - Q_2) = Q_2 - Q$$

Since the engine R_2 is reversible, it can be made to execute the cycle in the reverse by supplying W_{R2} .

Since $W_{R1} > W_{R2}$ the reversible engine R_2 can be run as a heat pump by utilizing part of the work delivered by R_1 .

For the combined device,

$W_{R1} - W_{R2} = Q_2 - Q$, by absorbing energy $Q_2 - Q$ from a single thermal reservoir which violates the second law of thermodynamics.

Hence $\eta_{R1} > \eta_{R2}$ is incorrect.

By similar arguments, if we assume that $\eta_{R2} > \eta_{R1}$ then,

$$\eta_{R1} \geq \eta_{R2}$$

Therefore, based on these two equations,

$$\eta_{R1} = \eta_{R2}$$

The efficiency of a reversible heat engine is also independent of the working fluid and depends only on the temperatures of the reservoirs between which it operates.

The Carnot cycle uses only two thermal reservoirs – one at high temperature T_1 and the other at two temperature T_2 .

If the process undergone by the working fluid during the cycle is to be reversible, the heat transfer must take place with no temperature difference, i.e. it should be isothermal.

The Carnot cycle consists of a reversible isothermal expansion from state 1 to 2, reversible adiabatic expansion from state 2 to 3, a reversible isothermal compression from state 3 to 4 followed by a reversible adiabatic compression to state 1.

The thermal efficiency, η is given by

$$\eta = \text{Net work done} / \text{Energy absorbed as heat}$$

During processes 2-3 and 4-1, there is no heat interaction as they are adiabatic.

$$Q_{1-2} = \int_1^2 Pdv = \int_1^2 RT_1 \frac{dv}{v} = RT_1 \ln(v_2 / v_1)$$

Similarly for the process 3-4,

$$Q_{3-4} = \int_3^4 Pdv = \int_3^4 RT_2 \frac{dv}{v} = RT_2 \ln(v_4 / v_3)$$

Net heat interaction = Net work done

$$= RT_1 \ln(v_2/v_1) + RT_2 \ln(v_4/v_3)$$

$$= RT_1 \ln(v_2/v_1) - RT_2 \ln(v_3/v_4)$$

The processes 2-3 and 4-1 are reversible, adiabatic and hence

$$T_1 v_2^{\gamma-1} = T_2 v_3^{\gamma-1}$$

$$\text{Or, } v_2/v_3 = (T_2/T_1)^{1/(\gamma-1)}$$

$$\text{And } T_2 v_4^{\gamma-1} = T_1 v_1^{\gamma-1}$$

$$\text{Or, } v_1/v_4 = (T_2/T_1)^{1/(\gamma-1)}$$

$$v_2/v_3 = v_1/v_4 \text{ or } v_2/v_1 = v_3/v_4$$

$$\eta = \{RT_1 \ln(v_2/v_1) - RT_2 \ln(v_3/v_4)\} / RT_1 \ln(v_2/v_1)$$

$$\eta = (T_1 - T_2)/T_1$$

$$= 1 - T_2/T_1$$

The Carnot Principles Cont'd

3.The efficiency of an irreversible heat engine is always less than the efficiency of a reversible one operating between same two thermal reservoirs.

4.The efficiencies of all reversible heat engines operating between the same two thermal reservoirs are the same.

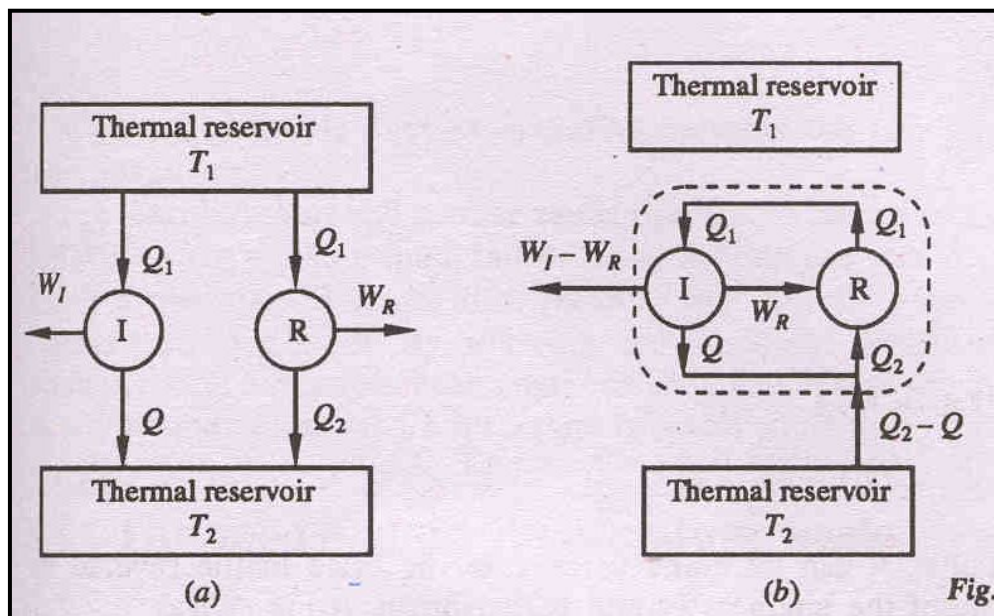

Lets us assume it is possible for an engine I to have an efficiency greater than the efficiency of a reversible heat engine R.

$$\eta_I > \eta_R$$

Let both the engines absorb same quantity of energy Q_1 . Let Q and Q_2 represent the energy rejected as heat by the engines R, and I respectively.

$$W_I = Q_1 - Q$$

$$W_R = Q_1 - Q_2$$

$$\eta_I = W_I / Q_1 = (Q_1 - Q)/Q_1 = 1 - Q/Q_1$$

$$\eta_R = W_R/Q_1 = (Q_1 - Q_2)/Q_1 = 1 - Q_2/Q_1$$

Since $\eta_I > \eta_R$,

$$1 - Q/Q_1 > 1 - Q_2/Q_1$$

or, $Q < Q_2$

Therefore, $W_I (= Q_1 - Q) > W_R (= Q_1 - Q_2)$

Since the engine R is reversible, it can be made to execute in the reverse order. Then, it will absorb energy Q_2 from the reservoir at T_2 and reject energy Q_1 to the reservoir at T_1 when work W_R is done on it.

If now engines I and R are combined, the net work delivered by the combined device is given by

$$W_I - W_R = Q_1 - Q - (Q_1 - Q_2) = Q_2 - Q$$

The combined device absorbs energy $(Q_2 - Q)$ as heat from a single thermal reservoir and delivers an equivalent amount of work, which violates the second law of thermodynamics.

Hence, $\eta_R \geq \eta_I$

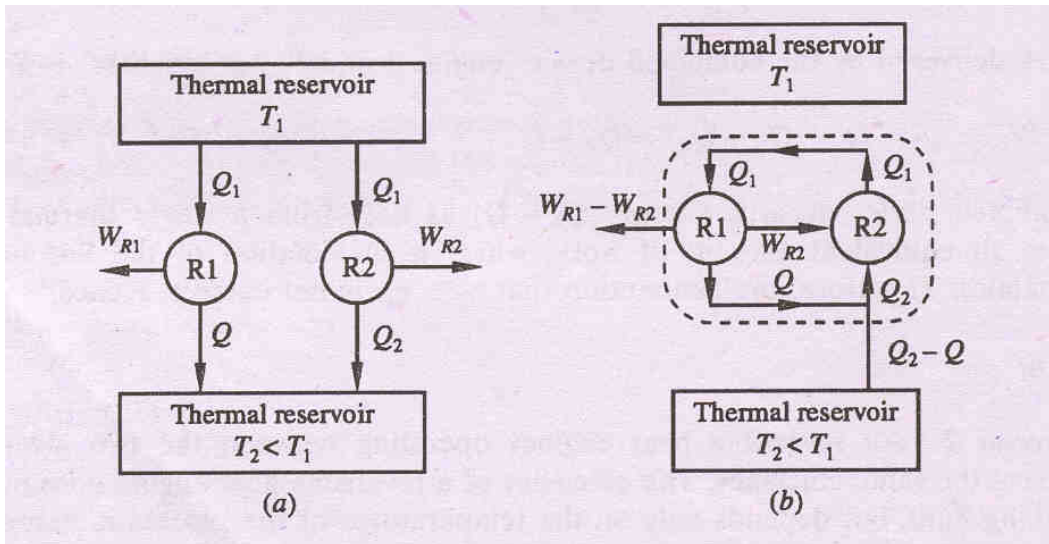

Carnot principle 2

Consider two reversible heat engines R_1 and R_2 , operating between the two given thermal reservoirs at temperatures T_1 and T_2 .

Let $\eta_{R1} > \eta_{R2}$

Q_1 = energy absorbed as heat from the reservoir at T_1 by the engines R_1 and R_2 , separately.

Q = energy rejected by reversible engine R_1 to the reservoir at T_2

Q_2 = energy rejected by reversible engine R_2 to the reservoir at T_2 .

$W_{R1} = Q_1 - Q$ = work done by a reversible engine R_1 .

$W_{R2} = Q_1 - Q_2$ = work done by a reversible engine R_2

According to assumption,

$$\eta_{R1} > \eta_{R2}$$

Or, $1 - Q/Q_1 > 1 - Q_2/Q_1$

$$Q_1 - Q > Q_1 - Q_2 \text{ or } W_{R1} > W_{R2}$$

$$W_{R1} - W_{R2} = (Q_1 - Q) - (Q_1 - Q_2) = Q_2 - Q$$

Since the engine R_2 is reversible, it can be made to execute the cycle in the reverse by supplying W_{R2} .

Since $W_{R1} > W_{R2}$ the reversible engine R_2 can be run as a heat pump by utilizing part of the work delivered by R_1 .

For the combined device,

$W_{R1} - W_{R2} = Q_2 - Q$, by absorbing energy $Q_2 - Q$ from a single thermal reservoir which violates the second law of thermodynamics.

Hence $\eta_{R1} > \eta_{R2}$ is incorrect.

By similar arguments, if we assume that $\eta_{R2} > \eta_{R1}$ then,

$$\eta_{R1} \geq \eta_{R2}$$

Therefore, based on these two equations,

$$\eta_{R1} = \eta_{R2}$$

The efficiency of a reversible heat engine is also independent of the working fluid and depends only on the temperatures of the reservoirs between which it operates.

5.0 ENTROPY

1. $\int \frac{dQ}{T}$ has the same value irrespective of path as long as path is reversible

2. $\left(\frac{dQ}{T}\right)_R$ is an exact differential of some function which is identical as entropy

$$3. S_2 - S_1 = \Delta S = \int_1^2 dS = \int_1^2 \left(\frac{dQ}{T} \right)_R$$

$$4. dS = \left(\frac{dQ}{T} \right)_R \text{ for reversible process only}$$

Calculation of Entropy change

1. Entropy is a state function. The entropy change is determined by its initial and final states only

2. In analyzing irreversible process, it is not necessary to make a direct analysis of actual reversible process.

Substitute actual process by an imaginary reversible process. The entropy change for imaginary reversible process is same as that of an irreversible process between given final and initial state.

(a) Absorption of energy by a constant temperature reservoir

Energy can be added reversibly or irreversibly as heat or by performing work.

$$\Delta S = \int \left(\frac{dQ}{T} \right)_R$$

Example:-

The contents of a large constant-temperature reservoir maintained at 500 K are continuously stirred by a paddle wheel driven by an electric motor. Estimate the entropy change of the reservoir if the paddle wheel is operated for two hours by a 250W motor.

Paddle wheel work converted into internal energy- an irreversible process. Imagine a reversible process with identical energy addition

$$\Delta S = \int \left(\frac{dQ}{T} \right)_R = \frac{Q}{T} = \frac{0.25 \times 2(3600)}{500} = 0.6 \text{ kJ}$$

(b) Heating or cooling of matter

$$Q = \Delta U \quad \text{for constant volume heating}$$

$$Q = \Delta H \quad \text{for constant pressure heating}$$

$$\Delta S = \int \frac{dQ}{T} = m \int_{T_1}^{T_2} C_p \frac{dT}{T} = mC_p \ln\left(\frac{T_2}{T_1}\right)$$

, for constant pressure

$$\Delta S = \int \frac{dQ}{T} = m \int_{T_1}^{T_2} C_v \frac{dT}{T} = mC_v \ln\left(\frac{T_2}{T_1}\right)$$

, for constant volume process

Example: -

Calculate entropy change if 1kg of water at 30⁰ C is heated to 80⁰C at 1 bar pressure. The specific heat of water is 4.2kJ/kg-K

$$\begin{aligned} \Delta S &= C_p \ln\left(\frac{T_2}{T_1}\right) = 4.2 \times 10^3 \times \ln\left(\frac{273+80}{273+30}\right) \\ &= 0.6415 \frac{kJ}{kg.K} \end{aligned}$$

(c) Phase change at constant temperature and pressure

$$S_{sf} = \int \frac{dQ}{T} = \frac{h_{sf}}{T}$$

$$S_{fg} = \int \frac{dQ}{T} = \frac{h_{fg}}{T}$$

Example:-

Ice melts at 0⁰C with latent heat of fusion= 339.92 kJ/kg. Water boils at atmospheric pressure at 100⁰C with h_{fg}= 2257 kJ/kg.

$$S_{sf} = \frac{334.92}{273.15} = 1.2261 \frac{kJ}{kg.K}$$

$$S_{fg} = \frac{2257}{373.15} = 6.0485 \frac{kJ}{kg.K}$$

Change of state for an ideal gas

If an ideal gas undergoes a change from P_1, v_1, T_1 to P_2, v_2, T_2 the change in entropy can be calculated by devising a reversible path connecting the two given states.

Let us consider two paths by which a gas can be taken from the initial state, 1 to the final state, 2.

The gas in state 1 is heated at constant pressure till the temperature T_2 is attained and then it is brought reversibly and isothermally to the final pressure P_2 .

Path 1-a: reversible, constant-pressure process.

Path a-2: reversible, isothermal path

$$\Delta s_{1-a} = \int dq/T = \int C_p dT/T = C_p \ln(T_2/T_1)$$

$$\Delta s_{a-2} = \int dq/T = \int (du + Pdv)/T = \int (Pdv)/T = R \ln(v_2/v_1)$$

(Since $du = 0$ for an isothermal process)

Since $P_2 v_2 = P_1 v_1 = P_1 v_a$

$$\text{Or, } v_2/v_1 = P_1/P_2$$

$$\text{Or, } \Delta s_{a-2} = -R \ln(P_2/P_1)$$

$$\begin{aligned} \text{Therefore, } \Delta s &= \Delta s_{1-a} + \Delta s_{a-2} \\ &= C_p \ln(T_2/T_1) - R \ln(P_2/P_1) \end{aligned}$$

Path 1-b-2: The gas initially in state 1 is heated at constant volume to the final temperature T_2 and then it is reversibly and isothermally changed to the final pressure P_2 .

1-b: reversible, constant volume process

b-2: reversible, isothermal process

$$\Delta s_{1-b} = C_v \ln(T_2/T_1)$$

$$\Delta s_{b-2} = R \ln(v_2/v_1)$$

$$\text{or, } \Delta s = C_v \ln(T_2/T_1) + R \ln(v_2/v_1)$$

The above equation for Δs can also be deduced in the following manner:

$$ds = (dq/T)_R = (du + PdV)/T = (dh - VdP)/T$$

In general,
 $dS \geq dQ/T$

or,

$$\begin{aligned} \Delta s &= \int_1^2 \frac{(du + PdV)}{T} = \int_1^2 \frac{C_v dT}{T} + \frac{R dV}{V} \\ &= C_v \ln \frac{T_2}{T_1} + R \ln \frac{V_2}{V_1} \end{aligned}$$

Similarly,

$$\Delta s = \int_1^2 \frac{(dh - VdP)}{T} = C_p \ln \frac{T_2}{T_1} - R \ln \frac{P_2}{P_1}$$

Principle of increase of entropy

Let a system change from state 1 to state 2 by a reversible process A and return to state 1 by another reversible process B. Then 1A2B1 is a reversible cycle. Therefore, the Clausius inequality gives:

$$\int_{1A2B1} dQ/T = \int_{1A2} dQ/T + \int_{2B1} dQ/T = 0$$

If the system is restored to the initial state from 1 to state 2 by an irreversible process C, then 1A2C1 is an irreversible cycle. Then the Clausius inequality gives:

$$\int_{1A2C1} dQ/T = \int_{1A2} dQ/T + \int_{2C1} dQ/T < 0$$

Subtracting the above equation from the first one,

$$\int_{2B1} dQ/T > \int_{2C1} dQ/T$$

Since the process 2B1 is reversible,

$$\int_{2B1} dQ/T = \int_1^2 dQ/T$$

Where the equality sign holds good for a reversible process and the inequality sign holds good for an irreversible process.

Now let us apply the above result to evaluate the entropy change of the universe when a system interacts with its surroundings and exchanges energy as heat with the surroundings.

Let T_{sur} and T_{sys} be the temperatures of the surroundings and the system such that $T_{\text{sur}} > T_{\text{sys}}$. Let dQ represent the energy transfer as heat from the surroundings to the system during the given irreversible process.

$$\begin{aligned}dS_{\text{sys}} &= dQ/T_{\text{sys}} \\dS_{\text{sur}} &= -dQ/T_{\text{sur}} \\dS_{\text{uni}} &= dS_{\text{sys}} + dS_{\text{sur}} = (dQ/T)_{\text{sys}} - (dQ/T)_{\text{sur}} > 0\end{aligned}$$

$$\Delta S_{\text{uni}} > 0 \text{ (since } T_{\text{sur}} > T_{\text{sys}})$$

If the system is isolated, there is no change in the entropy of the surroundings and $\Delta S \geq 0$, for an isolated system

Therefore the entropy of an isolated system either increases or, in the limit, remains constant.

The equality sign holds good when the process undergone by the system is reversible, the inequality sign holds good if there is any irreversibility present in the process. This statement is usually called the **principle of entropy increase**.

Irreversible or spontaneous processes can occur only in that direction for which the entropy of the universe or that of an isolated system, increases. These processes cannot occur in the direction of decreasing entropy.

For an isolated system,

$$\begin{aligned}\Delta S &> 0, \text{ for irreversible processes} \\ \Delta S &= 0, \text{ for reversible processes} \\ \Delta S &< 0, \text{ the process is impossible}\end{aligned}$$

Example:

One kg of superheated steam at 0.2MPa and 200°C contained in a piston cylinder assembly is kept at ambient conditions of 300K till the steam is condensed to saturated liquid at constant pressure. Calculate the change in the entropy of the universe with this process.

Solution:

Initial state of the steam: superheated at 0.2 MPa and 200°C

$$h_1 = 2870.4 \text{ kJ/kg}; \text{ and } s_1 = 7.5033 \text{ kJ/kgK}$$

Final state: saturated liquid at 0.2 MPa.

$$h_2 = 504.52 \text{ kJ/kg and } s_2 = 1.5295 \text{ kJ/kgK}$$

$$\text{Hence } \Delta S_{\text{steam}} = s_2 - s_1 = 1.5295 - 7.5033 = -5.9738 \text{ kJ/kgK}$$

For a constant pressure process: $q = \Delta h$

$$\text{Therefore, } q = h_2 - h_1 = 504.52 - 2870.4 = -2365.68 \text{ kJ}$$

$$\text{Entropy change of the surroundings} = \Delta S_{\text{sur}} = Q/T_{\text{sur}} = 2365.88/300 = 7.886 \text{ kJ/K}$$

$$\text{Hence, } \Delta S_{\text{uni}} = \Delta S_{\text{sys}} + \Delta S_{\text{sur}} = -5.9738 + 7.886 = 1.9122 \text{ kJ/K}$$

$\Delta S_{\text{uni}} > 0$ and hence the process is irreversible and feasible.

Temperature-Entropy diagram

Entropy change of a system is given by $dS = (dQ/T)_R$. during energy transfer as heat to the system from the surroundings is given by

$dQ = TdS$. Hence if T and S are chosen as independent variables, then the integral $\int TdS$ is the area under the curve.

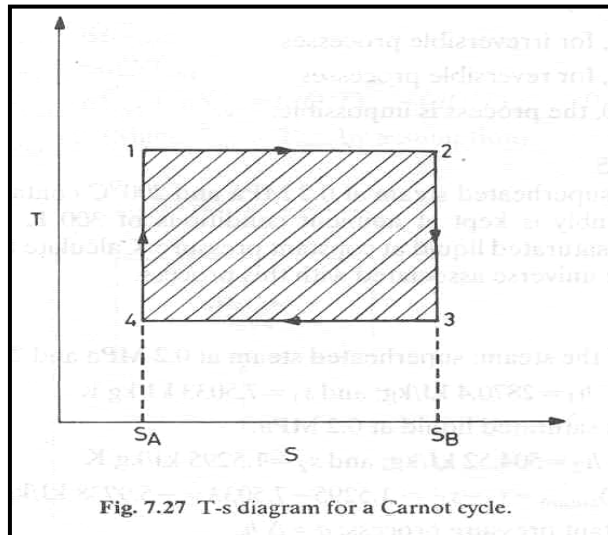

The first law of thermodynamics gives

$$dU = dQ - dW$$

also for a reversible process,

$S_G > 0$ for an irreversible process

Consider a control volume through which material flows continuously in and out. At time, t , the system constitutes both the mass inside the control volume and the mass about to enter the control volume during a small time interval dt .

$$\begin{aligned} \text{The entropy of the system} &= m(t)s(t) + \dot{m}_i s_i dt \\ &= S(t) + \dot{m}_i s_i dt \end{aligned}$$

At time $(t+dt)$ the entropy of the system

$$= m(t+dt)s(t+dt) + \dot{m}_e s_e dt = S(t+dt) + \dot{m}_e s_e dt$$

where,

$m(t)$ = mass inside the control volume at time t

$s(t)$ = specific entropy of matter inside the control volume at time t

$m(t+dt)$ = mass inside the control volume at time $(t+dt)$

$s(t+dt)$ = specific entropy of the mass inside the control volume at time $(t+dt)$

$$dQ = TdS \text{ and } dW = PdV$$

Therefore, $dU = TdS - PdV$

For a cyclic process, the above equation reduces to $\oint TdS = \oint PdV$

For a cyclic process, $\oint TdS$ represents the net heat interaction which is equal to the net work done by the system. Hence **the area enclosed by a cycle on a T-S diagram represents the net work done by a system.**

Second law analysis of a control volume

$$dS \geq dQ/T$$

where the equality sign holds good for reversible processes and the inequality sign holds good for all irreversible processes. This can be expressed as

$$\Delta S = dQ/T + S_G$$

where S_G represents the entropy generation in the system and it cannot take a negative value. $S_G = 0$ for a reversible process

$S(t+dt)$ = entropy of control volume at time $(t+dt)$

Then,

$$\left[S(t+dt) + \dot{m}_e s_e dt \right] - \left[S(t) + \dot{m}_i s_i dt \right] = \dot{Q} dt / T + \dot{S}_G dt$$
$$\frac{S(t+dt) - s(t)}{dt} + \dot{m}_e s_e - \dot{m}_i s_i = \dot{Q}/T + \dot{S}_G$$

$$\text{or, } dS/dt + \dot{m}_e s_e - \dot{m}_i s_i = \dot{Q}/T + \dot{S}_G$$

This can be rearranged as :

$$dS/dt = (\dot{m}_i s_i + \dot{Q}/T) - (\dot{m}_e s_e) + \dot{S}_G$$

or stated in words:

[The rate of accumulation of entropy] = [Rate of inflow of entropy] – [Rate of outflow of entropy] + [Rate of generation of entropy]

Example:

An inventor claims to have designed a device which takes in 2kmol/s of air at 250 kPa and 350 K and delivers equal amounts of hot stream of air at 100kPa and 400 K as also a cold stream of air at 100 kPa and 250 K. He further claims that

his device does not require any additional energy as heat or work to operate. Judge whether such a device is feasible or not. Consider air to be an ideal gas with $C_p = 7R/2$

Solution:

The first law of thermodynamics for a control volume gives:

$$\dot{m}_i h_i = \dot{m}_{e1} h_{e1} + \dot{m}_{e2} h_{e2}$$

$$\text{or } 2h_i = h_{e1} + h_{e2}$$

$$\text{or } (h_i - h_{e1}) + (h_i - h_{e2}) = 0$$

$$C_p(T_i - T_{e1}) + C_p(T_i - T_{e2}) = 0$$
$$(350 - 450) + (350 - 250) = 0$$

The first law is thus satisfied.

The second law of thermodynamics gives:

$$m_{e1} s_{e1} + m_{e2} s_{e2} \geq m_i s_i$$

The material balance gives

$$m_{e1} + m_{e2} = m_i$$

$$\text{Therefore } (m_{e1}s_{e1} + m_{e2}s_{e2}) \geq (m_{e1} + m_{e2})s_i$$

$$\text{Or, } m_{e1}(s_{e1}-s_i) + m_{e2}(s_{e2}-s_i) \geq 0$$

The change in entropy is given by

$$\Delta s = C_p \ln(T_2/T_1) - R \ln(P_2/P_1)$$

hence,

$$m_{e1}(s_{e1}-s_i) = C_p \ln(450/350) - R \ln(100/250)$$

and,

$$m_{e2}(s_{e2}-s_i) = C_p \ln(250/350) - R \ln(100/250)$$

then,

$$m_{e1}(s_{e1}-s_i) + m_{e2}(s_{e2}-s_i) = 12.7581 \text{ kJ/K} > 0$$

Hence it satisfies the second law of thermodynamics also Therefore the device is feasible.

6.0 THERMODYNAMIC RELATIONS

Gibbs Function and Helmholtz Function

Gibbs equation is

$$du = Tds - Pd v$$

The enthalpy h can be differentiated,

$$dh = du + pdv + vdP$$

Combining the two results in

$$dh = Tds + vdP$$

The coefficients T and v are partial derivative of $h(s,P)$,

$$\left(\frac{\partial h}{\partial s} \right)_P = T$$

$$\left(\frac{\partial h}{\partial P} \right)_s = v$$

Since $v > 0$, an isentropic increase in pressure will result in an increase in enthalpy.

We introduce Helmholtz function

$$a = u - Ts$$

Combine Gibbs equation with the differential of a ,

$$da = -Pd v - s dT$$

The coefficient $-P$ and $-s$ are the partial derivatives of $f(v,T)$, so

$$\left(\frac{\partial a}{\partial v} \right)_T = -P$$

$$\left(\frac{\partial a}{\partial T} \right)_v = -s$$

Similarly, using the Gibbs function

$$g = h - Ts$$

$$dg = v dP - s dT$$

Consequently,

$$\left(\frac{\partial g}{\partial P} \right)_T = v$$

$$\left(\frac{\partial g}{\partial T} \right)_P = -s$$

Note:

1. The decrease in Helmholtz function of a system sets an upper limit to the work done in any process between two equilibrium states at the same temperature during which the system exchanges heat only with a single reservoir at this temperature. Since the decrease in the Helmholtz potential represents the potential to do work by the system, it is also a thermodynamic potential.

2. The decrease in Gibbs function of a system sets an upper limit to the work, exclusive of “pdv” work in any process between two states at the same temperature and pressure, provided the system exchanges heat only with a single reservoir at this temperature and that the surroundings are at a constant pressure equal to that in the end states of the pressure.

The maximum work is done when the process is isothermal isobaric. Gibbs function is also called Chemical Potential.

Some important property relations

$$dz(x,y) = M dx + N dy$$

$$\text{where, } M = \left(\frac{\partial z}{\partial x} \right)_y \quad N = \left(\frac{\partial z}{\partial y} \right)_x$$

Mathematically, we would say that dz is an exact differential, which simply means that z is a continuous function of the two independent variables x and y . Since the order in which a second partial derivative is taken is unimportant, it follows that,

$$\left(\frac{\partial M}{\partial y} \right)_x = \left(\frac{\partial N}{\partial x} \right)_y$$

Maxwell's relations:

$$\left(\frac{\partial T}{\partial v}\right)_s = -\left(\frac{\partial P}{\partial s}\right)_v \quad [\text{From equation } du = Tds - Pdv]$$

$$\left(\frac{\partial T}{\partial P}\right)_s = \left(\frac{\partial v}{\partial s}\right)_P \quad [\text{From equation } dh = Tds + vdP]$$

$$\left(\frac{\partial P}{\partial T}\right)_v = \left(\frac{\partial s}{\partial v}\right)_T \quad [\text{From equation } da = -Pdv - sdT]$$

$$\left(\frac{\partial v}{\partial T}\right)_P = -\left(\frac{\partial s}{\partial P}\right)_T \quad [\text{From equation } dg = vdP - sdT]$$

Mnemonic Diagram

The differential expressions for the thermodynamic potentials and Maxwell relations can be remembered conveniently in terms of a thermodynamic Mnemonic diagram.

The diagram consists of a square with two diagonal arrows pointing upwards and the thermodynamic potentials in alphabetical order clockwise on the sides as shown in figure. The natural variables associated with each potential are placed in the corners.

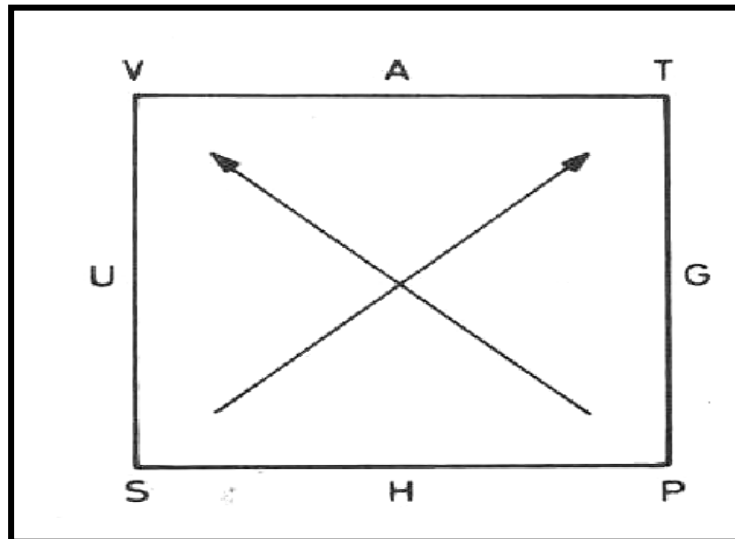

Diagonal arrows indicate the coefficients associated with the natural variables in the differential expression of the potential. The sign of the coefficient depends on whether the arrow is pointing towards (- ve) or away from the natural variable (+ ve).

For example,

$$du = (\text{sign})(\text{coeff.}) ds + (\text{sign})(\text{coeff.}) dv$$

$$du = (\text{sign})Tds + (\text{sign})Pdv$$

$$du = +Tds - Pdv$$

To write the Maxwell relations we need to concentrate on the direction of the arrows and the natural variables only.

If both the arrows pointing in the same direction, there is no need to change the sign, otherwise the equation should carry a negative sign.

The internal energy

$$u = u(T, v)$$

For a simple compressible substance,

$$du = C_v dT + \left(\frac{\partial u}{\partial v} \right)_T dv$$
$$ds = \frac{C_v}{T} dT + \frac{1}{T} \left[\left(\frac{\partial u}{\partial v} \right)_T + P \right] dv$$

Taking entropy as a function of temperature and volume,

$$\left(\frac{\partial s}{\partial T} \right)_v = \frac{C_v}{T}$$

Using third Maxwell's relation,

$$\left(\frac{\partial s}{\partial v} \right)_T = \left(\frac{\partial P}{\partial T} \right)_v = \frac{1}{T} \left[\left(\frac{\partial u}{\partial v} \right)_T + P \right]$$

From this we obtain

$$\left(\frac{\partial u}{\partial v} \right)_T = T \left(\frac{\partial P}{\partial T} \right)_v - P$$

This important equation expresses the dependence of the internal energy on the volume at fixed temperature solely in terms of measurable T, P and v. This is helpful in construction of tables for u in terms of measured T, P and v.

For a perfect gas,

$$Pv = RT$$

$$\left(\frac{\partial P}{\partial T}\right)_v = \frac{R}{v}$$

$$\left(\frac{\partial u}{\partial v}\right)_T = T \frac{R}{v} - P = P - P = 0$$

This implies that, for a perfect gas, internal energy is independent of density and depends only on T.

$$ds = \frac{C_v}{T} dT + \left(\frac{\partial P}{\partial T}\right)_v dv$$

Similarly it can be shown using Fourth Maxwell's relation that

$$ds = \frac{C_p}{T} dT + \left(\frac{\partial v}{\partial T}\right)_p dP$$

Using the above two equations and solving for dP,

$$dP = \frac{C_p - C_v}{T(\partial v / \partial T)_p} dT - \frac{(\partial P / \partial T)_v}{(\partial u / \partial T)_p} dv$$

Considering P as a function of T and v, we see that

$$\frac{C_p - C_v}{T(\partial v / \partial T)_p} = \left(\frac{\partial P}{\partial T}\right)_v$$

Two thermodynamic properties can be defined at this stage,

$$\beta \equiv \frac{1}{v} \left(\frac{\partial v}{\partial T}\right)_p$$

β is called the isobaric compressibility and κ is called the compressibility.

$$\kappa \equiv -\frac{1}{v} \left(\frac{\partial v}{\partial P}\right)_T \quad \text{isothermal}$$

From calculus, it can be shown that,

$$\left(\frac{\partial P}{\partial T}\right)_v \left(\frac{\partial T}{\partial v}\right)_P \left(\frac{\partial v}{\partial P}\right)_T = -1$$

or,

$$\left(\frac{\partial P}{\partial T}\right)_v = -\frac{(\partial v / \partial T)_P}{\left(\frac{\partial v}{\partial P}\right)_T} = \frac{\beta}{\kappa}$$

Therefore,

$$C_P - C_v = -\frac{T \left[(\partial v / \partial P)_P \right]^2}{(\partial v / \partial P)_T}$$

Since $(\partial v / \partial P)_T$ is always negative for all stable substances, C_P is always greater than C_v .

BIBLIOGRAPHY

1. www.codecogs.com/reference/engineering/thermodynamics/first_law_of_thermodynamics.php
2. http://www.engineersedge.com/thermodynamics/second_law.htm
3. <http://en.wikipedia.org/wiki/Thermodynamics>
4. Osore O.A. (1999). Essentials of Classical Thermodynamics. IPS Educational Press, P.M.B 173, Ilaro, Ogun state, Nigeria.