

COURSE CODE:	<i>MCE 405</i>
COURSE TITLE:	<i>Machine Design I</i>
NUMBER OF UNITS:	<i>3 Units</i>
COURSE DURATION:	<i>6 hours (Three hours lecture, three hours practical) per week</i>

COURSE DETAILS:

Course Coordinator:	Engr. Adekunle, N .Olatunde B.Sc, M.Sc.
Email:	noadekonle@yahoo.com
Office Location:	Room 4 PG School
Other Lecturers:	None

COURSE CONTENT:

Philosophy of design. Design as problem solving. Components of design. Creative design . Detail design (quantitative and qualitative). Stress and deflection analysis . Design against failure. Engineering materials . Power screws . Detachable fasteners. Shafting design . Design project

COURSE REQUIREMENTS:

This is a compulsory course for all students in engineering. In view of this, students in the college of engineering are strongly advised to attend classes regularly and have a minimum of 75% attendance to be eligible to write the final examination.

READING LIST:

LECTURE NOTES

LECTURE ONE

1. **Adaptive design** deals with the use of existing or adapting available designs. No need of prior knowledge minor alteration or modification can be made to the existing design.
2. **Development design** –a broad knowledge of scientific training is needed to be able to modify the existing design into a new idea or innovation by making use of new material or modern man factor process or method thereby improving the quality of new products.
3. **New design** –this is achieved through a lot of researches technical ability and well developed mind or creative think.

The design classification methods.

Rational design –depends upon mathematics formulae of principle of mechanics.

Empirical design –base on empirical formulae deduce from practical carried out and past experience of the designer.

INDUSTRIAL DESIGN; it is usually depends upon the production aspect of manufacturing

OPTIMUM DESIGN –best for a special product or for objective function subjected to a constraint. It can be achieved by minimizing the undesirable effects.

SYSTEM DESIGN –specifically for any complex mechanical system like a motor car.

ELEMENT DESIGN –specifically for a given component or machine elements e.g. application of computer system to assist in the creation, modification, analysis and optimization of a given design.

General considerations in M/C design

Types of load – Dead load, live load dynamic load.

Types of stresses –internal, external, thermal

Motion of parts or kinematics of the machine

Rectilinear motion (uni direction and reciprocating)

Curvilinear motion (rotary, oscillatory and simple harmonic motion).

Constant velocity,

Constant or variable acceleration.

Selection of Materials

Thorough knowledge of the properties of the materials and their behavior under working conditions is essential in design (physical and mechanical) form and size of the parts. Frictional resistant power loss give to friction during starting must be considered (lubrication of rotating parts) convenient and economical features –starting controlling stopping levers should be located on the basis of convenient handling use of standard parts –to reduce cost e.g. Bolts and studs.

Safety of operations –safety device for the operator. Workshop should be avoided to safe time.

Number of machines to be manufactured –this is the number of articles or elements to be produced affects the design in number of ways.

Cost of construction –the aim of design engineer under all conditions, should be to reduce the manufacturing cost to the minimum.

Assembling –here all the machine parts or elements are put together to form a unit product before it can function. it is advisable that large units must often be assembled in the workshop, tested and then transported to their place of service. The final location of any machine is very important, that is exact location must be known together with the local facilities for erection of the product.

LECTURE TWO

Engineering Materials

INTRODUCTION

All engineers deal with materials on a daily basis. Their multidisciplinary roles of designing, manufacturing, processing, constructing or fabricating structures or components, management and research, to mention a few, require a sound understanding of both the service and manufacturing properties of engineering materials. It is equally important to note that an improvement in the performance of the product designed or manufactured can easily be achieved through better choice of materials.

In the early times man has been heavily dependent on materials for tools, clothing, and shelter. In a typical day, the average modern man is in contact with hundreds of materials: wood, metals, polymers, glasses and ceramics. Transportation, housing, clothing, communication, recreation, food production, medical care, indeed, virtually every segment of our everyday is influenced to one degree or another by materials,

The early man had access to only a very limited number of materials, those that occur naturally: wood, clay, and skins. With time he developed techniques for producing materials that had properties superior to those of the natural ones. These raw materials included pottery, non-ferrous and ferrous metals. He also discovered that the properties of a material can be altered by heat treatments and by the addition of other substances. For example, the properties of clay were greatly improved by mixing with straw and fibre, the very humble beginnings of composite materials technology. At these initial stages of development, primary problem was one of selection from a rather limited set of materials the most appropriate for a given application.

It was not until relatively recent times that materials scientists came to understand the relationships between the structural elements of materials and their properties. The knowledge acquired in about the past 60 years has empowered the materials engineer to fashion to a large degree the characteristics of materials to suit given applications. This has led to the development of tens of thousands of different materials, probably over 50,000 metals and alloys and as many non-metals. The arduous and challenging task in materials engineering remains essentially selection of materials for a given application from wide range of options, based on the service requirements, and economic requirements, materials behaviour in service. These are premised on the dire need to maximize performance.

General Classification of Materials

Material selection for Engineering Component.

Review of both Physical and Mechanical properties of Materials

Materials classification

Metals

Ferrous Metals and Non Ferrous Metals

Metal Alloys

Non Metals eg. Glass ,Rubber and Ceramics.

Metals; Aluminium, Copper, Steel, Zinc, and the like have desirable properties such as good thermal and electrical conductivity, high ductility or formability, high stiffness, relatively high strength and good shock resistance.

Ceramics

This is a group of materials characterised by good strength and high melting temperature but poor ductility and electrical conductivity. Examples include bricks, glass, tableware, abrasives and insulators. Ceramic raw materials are typically components of metallic and non-metallic elements. They are suited for molten metal and other high temperature applications.

Composites

This can be regarded as a combination of two or more materials which are used in combination to rectify a weakness in one material by strength in another. Examples include plywood, fibreglass, and concrete.

Polymers

Polymers such as plastics, rubber and various types of adhesives are produced by creating large molecular structures from organic molecules, obtained from petroleum or agricultural products. They are characterised by low strengths; low melting temperatures and poor electrical conductivity. However, polymers have excellent resistance to corrosion.

Processing of Materials

Processing techniques for metals include casting; welding, brazing, soldering and adhesive bonding; forging, drawing, extrusion, bonding and rolling; powder metallurgy and machining.

Ceramics are processed through related processes like forming, casting, extrusion or compaction while polymers are processed by moulding, forming and drawing.

Materials Selection

Selection of engineering materials involves thorough investigation and compromise that weighs relative suitability and limitations. The final choice of material is normally arrived at after a thorough consideration of the service requirement, fabrication requirement, availability and economic requirement.

Materials Selection

Availability of Materials

Suitability of Material under working condition or service

Cost of producing the materials

Physical Properties of Materials.

Luster ,Colour, size ,Density , Shape ,Boiling Point ,Melting Point ,Electric Conductivity ,Thermal Conductivity, Coefficient of friction.

Mechanical Properties of Materials

Strength ,Stiffness ,Hardness, Ductility, Plasticity, Brittleness, Elasticity, Toughness , Creep ,Fatigue , Malleability, Resilience.

MECHANICAL TESTING OF MATERIALS

Hardness test: Brinell hardness test and Vicker's hardness test.

Impact test: Charpy or Izod

Fatigue test, creep test and tensile test.

Lecture Three

Stresses in Engineering Elements : Normal Stress , Tensile Stress, Shear Stress

Formulae for finding Stresses

SIMPLE STRESSES

TENSILE STRESS:

TENSILE AND COMPRESSIVE STRESSES

SHEAR STRESS

TORSIONAL STRESS

BENDING STRESS

PLANE STRESS

PLANE STRESS

⊙ Bi Axial Stresses

Tri Axial Stresses

Determination of Principal Stresses and Plane of Maximum Stress

Determination of Maximum Shear Stress

LECTURE FOUR

Failure of Engineering Materials

INTRODUCTION

Failure analysis deals with the determination of the causes of the failure of engineering parts or component. Failure can be defined as the inability of a component to function properly, and this definition does not imply fracture.

LECTURE FIVE

Shaft Design

Rotating machine element which is used to transmit power from one place to another.

General properties of materials used for shafts.

Types of Shafts – Transmission, Machine Shafts.

Stresses developed in shaft during operation :

Maximum permissible working stresses for Transmission shaft.

Design of shaft on the basis of strength, Rigidity and stiffness

Shaft Design on basis of Strength

Case 1 Shaft subjected to twisting moment or torque, bending moment, axial loads in addition to combined tensional and bending moment

Application of maximum normal stress theory,

Application of shear stress theory,
Application of Deformation theory,
Application of Maximum strain Energy theory under static load

LECTURE SIX

Power Screw

Power Screws are used for providing linear motion in a smooth uniform manner. They are linear actuators that transform rotary motion into linear motion. Power screws are generally based on Acme, Square, and Buttress threads. Ball screws are a type of power screw. Efficiencies of between 30% and 70% are obtained with conventional power screws. Ball screws have efficiencies of above 90%.

Power Screws are used for the following three reasons:

- To obtain high mechanical advantage in order to move large loads with minimum effort. e.g Screw Jack.
- To generate large forces e.g A compactor press.
- To obtain precise axial movements e.g. A machine tool lead screw

SQUARE FORM

This form is used for power/force transmission i.e. linear jacks, clamps. The friction is low and there is no radial forces imposed on the mating nuts. The square thread is the most efficient conventional power screw form.

It is the most difficult form to machine.

It is not very compatible for using split nuts-as used on certain machine tool system for withdrawing the tool carriers

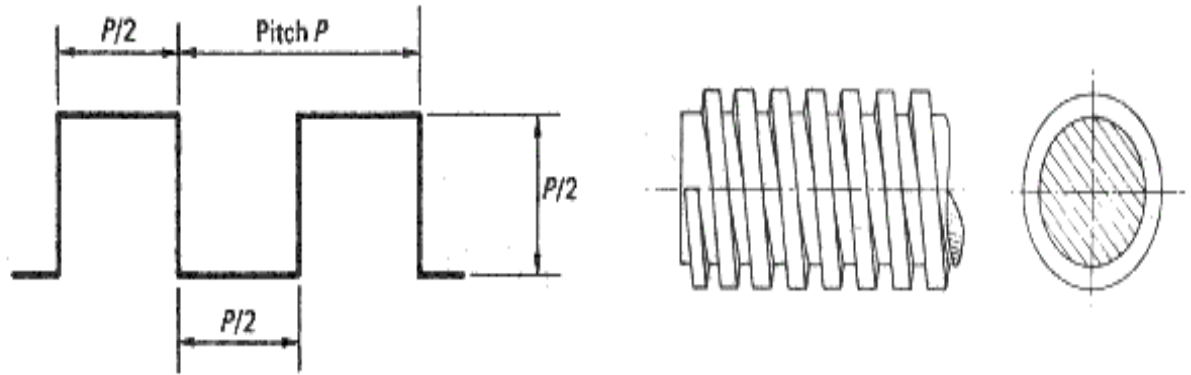

ACME FORM

Used for power transmission i.e. lathe lead screws. Is easier to manufacture compared to a square thread.

It has superior root strength characteristics compared to a square thread.

The acme screw thread has been developed for machine tool drives.

They are easy to machine and can be used with split nuts.

The thread has an optimum efficiency of about 70% for helix angles between 25° and 65° .

Outside this range the efficiency falls away.

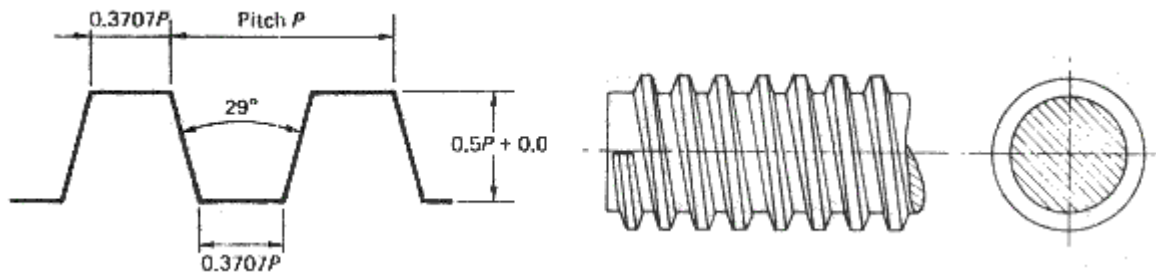

BUTTRESS FORM

A strong low friction thread. However it is designed only to take large loads in one direction.

For a given size this is the strongest of the thread forms. When taking heavy loads on the near vertical thread face this thread is almost as efficient as a square thread form

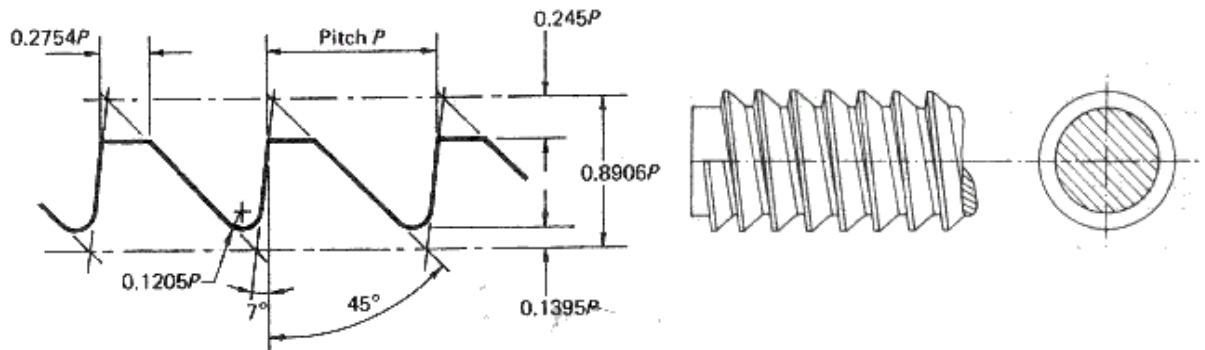

RECIRCULATING BALL SCREW

This type of power screw is used for high speed high efficiency duties. The ball screw is used for more and more applications previously completed by the conventional power screws. The ball screw assembly is as shown below and includes a circular shaped groove cut in a helix on the shaft.

Advantages of Recirculating Ball Screw

High Efficiency - Over 90%

Predictable life expectancy -

Precise and repeatable movement

No tendency for slip-stick

Minimum thermal effects

Easily preloaded to eliminate backlash-with minimum friction penalty

Smoother movement over full travel range ,Smaller size for same load

Disadvantages Recirculating Ball Screw

Requires higher levels of lubrication

Tend to overhaul- Needs additional brakes if locking is required

Susceptible to contamination

For the same capacity ball screws are not as rigid as conventional power screw

OVERHAULING

Overhauling occurs when the screw helix angle is such that the load W would cause to screw to rotate when the rotating force $F = \text{zero}$ i.e. the Force is not only required to raise the load - it is also required to statically support the load .

LECTURE SEVEN

Detachable Fasteners

Example of Detachable Fasteners: Keys, Cotter Pins, Knuckle Pins, Pin Joints.

Types of Keys: Sunk Keys, Saddle Keys, Tangent Keys, Round Keys, Splines .

Design of (1) Rectangular Sunk Key (2) Square key (3) Parallel Sunk Key (4) Gib-head Sunk

Areas of application of Sunk Keys.

Determination of Forces acting on a sunk key.

Determination of Strength of sunk key Determination of Permissible Crushing stress,

Determination of permissible shearing stress,

Determination of Torque transmitted by the key.

Areas of application of Sunk Keys.

Determination of Forces acting on a sunk key.

Determination of Strength of sunk key Determination of Permissible Crushing stress,

Determination of permissible shearing stress,

Determination of Torque transmitted by the key.

Coupling Design.

Design of sleeve or Muff-coupling

Design for sleeve,

.Design for key

Design for clamps or compression coupling –

Design for Muff, key, clamping bolts, design for flange.