

# **MCE 511 COMPUTER AIDED DESIGN AND MANUFACTURING E - NOTE**

**3 Units**

**Course Lecturer - Engr. Prof. Sam. B. ADEJUYIGBE**

## **INTRODUCTION**

The technology that has the greatest impact on the production system over the last decades is computer technology. For any meaningful technological, or industrial design, or manufacturing breakthrough in developing countries like Nigeria, it is time to abandon the old traditional ways of manual preparation in favour of more consistent and faster tool as Computer-Aided Design/Drafting/Manufacturing/Process Planning/Computer Aided Engineering (CAD/CADD/CAM/CAPP/CAE), so that fast accurate data drawings and manufactured products can be correctly obtained in good time.

The basic concepts, challenges and motivation of Computer-Aided Engineering (CAE) in developing countries like Nigerian is looked at in this paper using twenty six (26) Industries scattered in the Southern part of Nigeria.

National and International competition in manufacturing is causing industrial leaders to look at new strategies for remaining competitive and improving quality in their products. Developments in the computer industry are having profound impact on the manufacturing industries from design to machine processing as well as the management and marketing components.

Governments of all industrialized countries place great emphasis on the development of their manufacturing sectors. It is great importance, not only as a means of supporting sustainable growth, but also because of the nature of the technological developments that have taken place particularly over the last decade. Industrialization has a particular significant role to play in the amelioration of power and unemployment. Acceleration of industrial development of any nation depends on maximum utilization of Industrial Automation and Computer Aided Engineering (CAE). Therefore, the Nigerian Industries will have to imbibe the Computer Aided Engineering and its entire facet for improved productivity and rapid product development

The trend in manufacturing call for the development of the following modern day manufacturing systems. There are:

- Global competition in the manufacturing market;
- Customers now demanded high-quality goods, with low production cost and timely delivery of manufacturing products.
- Increase in the variety of products produced, thereby choosing the product life cycles to be shorter.

Therefore, the modern day technology that manufacturing systems make use of are discussed in this write up..

Manufacturing system entails a large number of interdependent activities consisting of distinct entities such as materials, tools, machine, power, and human beings. It is a complex system because it is comprised of many diverse physical and, human elements. The choice are many,

so the manufacturing engineers should be able to select correct which one to choose, that will profit the whole manufacturing system.

## **BASIC CONCEPTS**

Computers are widely used throughout manufacturing industry. Hence in this paper introduction is made to all the relevant basic concepts of the computer applications to

### **COMPUTER**

Computer is a machine that handles information with amazing speed. It works with such information as names and address book titles, lists of item sold in stores, mathematical problems and weather forecasts. It handles information in the form of numbers. It solves problems dealing numbers. The fastest computers can do millions of problems in a few seconds (4,5,6).

A computer by definition simply adds, subtracts, compares and store data. Computers are universally recognized as the most powerful and effective tool for improving productivity in industry, which is the single, most important concern of every manufacturing manager.

Computers excel in three areas of manufacture namely:

- Collecting information:
- Reaching a decision; and
- Issuing and order.

### **COMPUTER – AIDED ENGINEERING (CAE)**

CAE systems can provide support to businesses. This is achieved by the use of reference architectures and their ability to place information views on the business process. Reference architecture is the basis from which information model, especially product and manufacturing models.

Computers are used throughout as an aid in the manufacturing process. Some of the engineering application of computer is manufacturing fall mainly into the following areas of Computer Aided Engineering (CAE) which comprises all area of:

- Computer Aided Design [CAD];
- Computer Design and Drafting (CADD) ;
- Computer Aided Manufacturing [CAM];
- NC, CNC, AND DNC Machines;
- Computer Material Handling System (Robotics) ;
- Computer Aided Plant Layout (CAPL);
- Computer Aided Design/Manufacturing (CAD/CAM) ;
- Computer Integrated Manufacturing [CIM];
- Computer Aided Process Planning and Control [CAPPC]
- Computer Aided Material Handling (CAPM);
- Computer Aided Quality Assurance (CAQA);
- Computer Aided Maintenance Management (CAMM);

- Computer Aided Costing (CAC);
- Computer Aided Quality Management (CAQM);
- Computer Aided Production Control and Management (CAPCM);
- Computer Aided Software Engineering (CASE);
- Knowledge Based Expert System;
- Artificial Intelligence (CAAI);
- Virtual Reality (CAVR);
- Mechatronics; and
- Automation.

The CAD system is the most important initial source of the product data that is used subsequent CAE operations. CAD, CAQA, CAPM and CM systems create and/or collect data, which is used to control or monitor other aspects of the manufacturing process. The need to re-program at each of manufacturing is avoided by the use of standard form of data already stored in the computer by CAD. This method eliminates human error, and save a lot of time. The ability to link all the various activities/operations together, through common database, is known as Computer-Integrated Manufacturing (CIM).

### **CAE fields and phases**

CAE areas covered include:

- Stress analysis on components and assemblies using FEA (Finite Element Analysis);
- Thermal and fluid flow analysis Computational Fluid Dynamics (CFD);
- Kinematics;
- Mechanical Event Simulation (MES).
- Analysis tools for process simulation for operations such as casting, moulding, and die press forming.
- Optimization of the product or process.

In general, there are three phases in any Computer-Aided Engineering task:

- **Pre-processing** – defining the model and environmental factors to be applied to it. (typically a finite element model, but facet, voxel and thin sheet methods are also used)
- **Analysis solver** (usually performed on high powered computers)
- **Post-processing** of results (using visualization tools)

This cycle is iterated, often many times, either manually or with the use of commercial optimization software.

### **CAE in the automotive industry**

CAE tools are very widely used in the automotive industry. In fact, their use has enabled the automakers to reduce product development cost and time while improving the safety, comfort, and durability of the vehicles they produce. The predictive capability of CAE tools has progressed to the point where much of the design verification is now done using computer simulations rather than physical prototype testing. CAE dependability is based upon all proper assumptions as inputs and must identify critical inputs (BJ). Even though there have been many advances in CAE and it is widely used in the engineering field. Physical testing is still used as a

final confirmation for subsystems due to the fact that CAE cannot predict all variables in complex assemblies (i.e. metal stretch, thinn

## **COMPUTER – AIDED DESIGN (CAD)**

Computer Aided Design (CAD) is defined as the use of computer system to assist in creation, modification analysis or optimization of design (8). Computer – based systems are used for creating, modifying and communicating a plan or product design (9)

Activities performed by CAD include:

- Engineering design:
- Design analysis: and
- Design presentation.

CAD systems have become more intelligent. Many potential customers are focusing less on geometry creation and more on integration (10)

The CAD software consists of the computer programs to implement computer graphics on the system plus application program to facilitate the engineering functions of the user company. The process design is characterized by an iterative procedure which consists of identifiable steps or phase thus.

- Recognition of need – that a problem exists
- Definition of problem – specification
- Synthesis – conceptualized the component
- Analysis and optimization
- Evaluation – measuring the design against specification
- Presentation – documentation for example, drawing etc.

The above mentioned related design tasks can be performed by the use of modern Computer – Aided Design System. The CAD hardware typically includes.

- The Computer
- One or more graphics display terminal
- Keyboard; and
- Other peripheral equipment

A typically commercially available CAD system consists of the following components.

- One or more design workstations
- Processor;
- Plotter and or other input devices

The benefits derived from the use of CAD system are numerous some are enumerated below thus;

- Improved quality
- Designers can monitor the progress of a problem solution and terminate the run or modify the input data as required.
- Reduction of rafting labour:
- Reduction of turn around time:

- The designer can make subjective decisions at critical branch points, which guide the computer in continuing the problem solution:
- Reduction in the number of drawings required:
- Direct cost savings;
- High accuracy (to-one-millionth of a unit):
- Improvement in the general flow of information through a company:
- Provision of more reliability in design work by having relevant information's:
- The drawing speed increased up to three times faster drafters using traditional tool:
- Evaluation of alternative design
- Use of standard libraries "copy repeats"
- Modification of the CAD is quick and easy;
- Generation of rotations, bills of materials, and materials and symbols be placed on drawing savings valuable time: and
- Designers can immediately see and correct any gross errors in their drawings or input statements.

### **COMPUTER – AIDED DESIGN AND DRAFTING (CADD)**

The engineering drawing has been an integral part of industry for many years. It is the link between engineering design and manufacturing. Design information is quickly communicated to manufacturing in the form of drawings prepared according to prescribed drafting standards. Drawing can be classified into two categories (12, 13) thus:

- Logic drawing: Electric circuit diagrams; process sheets, etc.
- Geometric drawings: Mechanical drawing: Architectural drawing, maps, and printed circuit tools.

Traditionally drafting instrument has been, used to apply lead or ink or vellum or mayler or the use of pencil, scale and T-square. The popular alternative now is to prepare the drawing with the aid of a computer. A CAD system is a tool of the drafter. The combination of equipment to operate a CAD system is referred to as the workstation. It includes a computer, CAD software, display screen, input devices and copy devices

Other names for CADD are:

- Computer – Assisted Drafting
- Computer – Augmented Drafting; and
- Computer – Automated Drafting.

A CAD drawing is in fact, a database of graphic and textual information. The computer can be directed to develop a three – dimensional drawing, or picture of the object. It can be rotated through any desired angle. In addition, it can be sectioned at any point. This section can be rotated to expose the inside of the object under consideration. If changes are to be made, they are made and the section portion rotated and joined with its mating part. The next step is to direct the computer to make blue print (hard copy) of the object that has been designed.

A CADD programs contains hundreds of functions that enable you to accomplish specific drawing tasks. A task may involve drawing an object editing and existing drawing, displaying a view of the drawing, printing and savings it, or controlling other operation of the computer. The CADD modules include:

- Draw, edit, data output, system control, data storage and management and specific features

The software requirements for CADD depend on a matter of choice after careful study of the various options. These are various software option available such as:

- Micro station, Autocad, Turbocad, Archicad, Drafix window Scad, Floor plan plus, 3D Home Architect, etc.

There are also enhancement programs such as

- Corel Draw, 3D studio, Auto Desk, Animator and Adobe Illustrator. What is important here is to analyze your interest and needs and look for the software are that meet them.

## **COMPUTER-AIDED MANUFACTURING (CAM)**

Computer Aided Manufacturing (CAM) is a natural extension of the technology of Computer Aided Design (CAD). CAM is the use of computers and computer technology to assist in all phases of manufacturing a product, including process and production planning, machining, scheduling, management, and quality control

Computer-Aided Manufacturing (CAM) has attracted so many definitions, some of them are reviewed below thus:

- As the use of computer systems to plan, manage and control the operations of manufacturing plant through either direct or indirect computer interface with the plant's production resources.
- The Computer-Aided Manufacturing (CAM) facility is a natural extension of the technology of CAD, CAM can be defined as a plan for utilizing numerically controlled machines such as mills, lathes, drills, punches, and other programmable production equipment controlled by computers. Computers are also used in a CAM facility to control production scheduling and quality control, as well as the business functions of manufacturing such as purchasing, financial planning and marketing.
- CAM is the effective use of computer technology in the planning, management, and control of manufacturing function. The planning, management and control of the manufacturing systems involved in CAM are linked together at the shop floor.
- CAM include the use of a digital computer to enhance the shop floor manufacturing process, including monitoring and control of machining equipment shop floor information systems with automatic data gathering are part of a CAM system.

**CAM** is the use of computers and computer technology to assist in all phases of manufacturing a product, including process and production planning, machining, scheduling, management, and quality control

## **THE APPLICATION OF CAM**

The ultimate application of CAM occurs when the various operations and routings needed to allow production of the product are automatically from the CAD data, a process commonly referred to as Computer Aided Process Planning (CAPP). The application of CAM can be divided into two broad categories:

### **Manufacturing Planning (Monitoring)**

In manufacturing planning or monitoring, the computer is used indirectly to support the production function, but there is no direct connection of interface between the computer and the manufacturing process. The computer is used "of-line" to provide information for the effective of production activities.

The application of CAM in this category includes;

- (i) Cost Estimating;
- (ii) Computer –Aided Process Planning (CAPP)
- (iii) Computerized Machinability Data Systems;
- (iv) Computer-Assisted NC Part programming;
- (v) Development of Work Standards;
- (vi) Computer-Aided Line Balancing; and
- (vii) Production and Inventory Planning.

**Manufacturing Control**

This is the second application of CAM and it is concerned with developing computer system for implementing the manufacturing control functions. Manufacturing control is concerned with managing and controlling the physical operations in the factory. Process control, quality control, shop floor control, and process monitoring are all included within the scope of this function.

Computer process control includes;

- Transfer line;
- Assembly system;
- Numerical control;
- Robotics;
- Material handling; and
- Flexible manufacturing system.

Also, shop floor control reverse to production management techniques for collecting data form factory operations and using the data to help control production and inventory in the factory. This is shown in Fig, 13.2 below,

Another classification of application of CAM centers around four main area;

- (i) Numerical control (NC);
- (ii) Process planning;
- (iii) Robotics; and
- (iv) Factory management

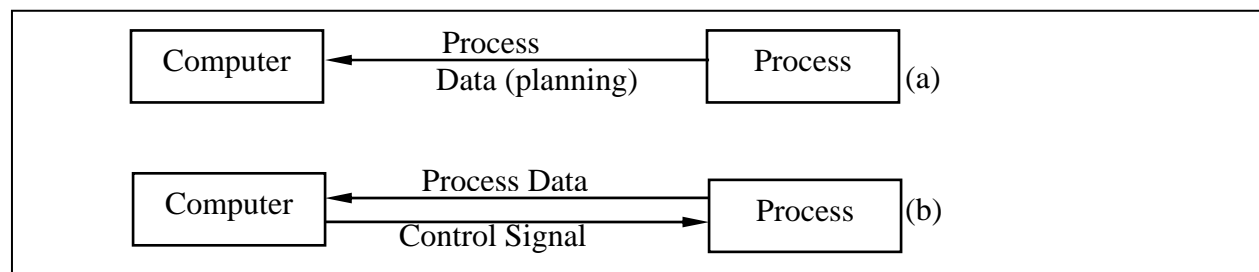

Fig. 13.2 Computer Monitoring (Planning) versus Computer Control  
 (a) Computer Monitoring (Planning)  
 (b) Computer control.

The use of computer is seen throughout the manufacturing process. Mechanical CADD is part of the much broader concept of Computer-Aided Manufacturing (CAM). At first, Computer- Aided Design (CAD) systems are used to define the geometry of the object. This geometry is then converted to Numerical Code (NC) by an NC processor. The code is read by a controller, connected to a milling machine or lathe, to direct the speed and direction of the machine tool.



CAM speeds up the manufacturing process since the same information used to create the design is used by machinery to machine the part before being sent to a machine, the numerical code can be used for machine to simulate using this type of program, the computer displays the tool path on the screen. Errors in tool movement can be detected before part is machines. If the tool moves too fast or too deep, the designer can edit the tool path.

### AN INTEGRATED CAD/CAM

CAD/CAM is a term which means Computer-Aided Design and Computer-Aided Manufacturing. It is the technology that concerned with the use of digital computers to perform certain functions in design and production process to improve productivity. This technology is moving in the direction of greater integration of design and manufacturing, two activities which have traditionally been treated as distinct and separate function in production form. Ultimately, CAD/CAM will provide the technology base for the computer-integrated factory of the future.

The scope of CAD/CAM in the operations of a manufacturing firm and the product cycle is presented in Fig. 13.3. Except for engineering changes which typically follow the product in all of the different activities in the product cycle.

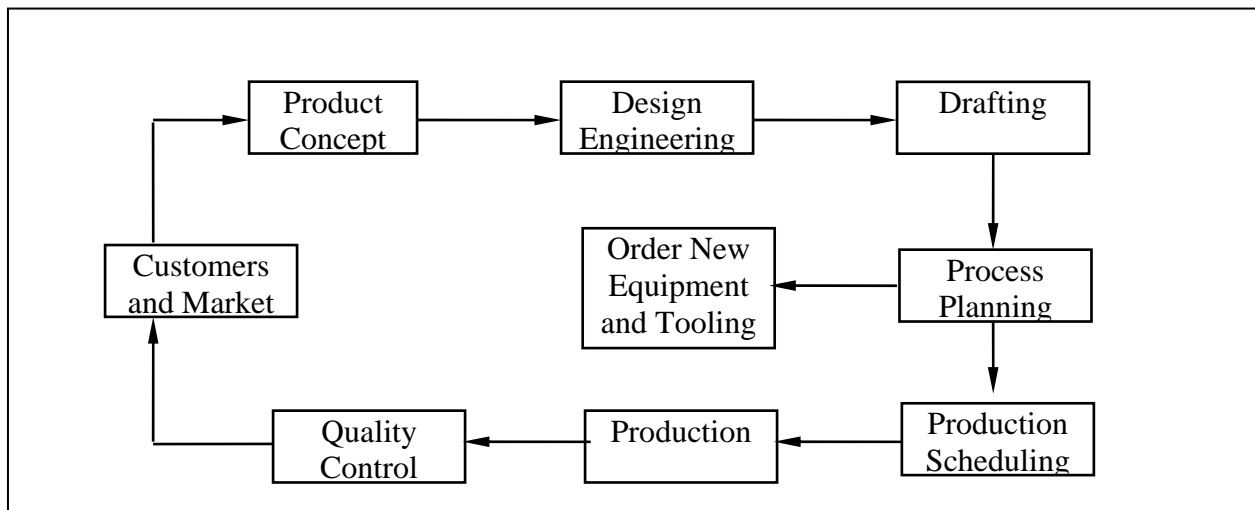

Fig. 13.3. Product Cycle (Design and Manufacturing)

### ADVANTAGES OF USING CAM

Some advantages for using CAM includes;

- (i) Communications are improves by the direct transfer of documentation from design to manufacturing.
- (ii) Production is increased and more efficient
- (iii) Errors are reduces with the same data base used by design an manufacturing.
- (iv) Material handling and machine processing are more efficient;
- (v) Quality control is improves
- (vi) Leads items are reduced, improving market responses and
- (vii) Work environment is safer and more humans

## **CAD SOFTWARE DESIGN**

Software is defined as the set of written instruction, procedure and rules that direct the operation of the computer. Software is another name for programs. The names are interchangeably used until ROM (Read-Only Memory) chips were introduced. A computer software include the instructions which enable the computer hardware to carry out specific task. It is the instructions that tell the computer how to process data. The set of instructions that a computer follow to solve a problem is called a computer program. Program stored in ROM are termed firmware, since they cannot be altered, while the programs on files are software. The two kinds of software are:

- (i) Application software; and
- (ii) System software.

Application software is known as “end users” software. It is used for useful work and general purpose tasks, for example work processing. While system software is the background software that helps the software and the computer, for example running (“executing”) programs. Storing data, programs, and processing data.

Software tools that have been developed to support these activities are considered CAE tools. CAE tools are being used, for example, to analyze the robustness and performance of components and assemblies. The term encompasses simulation, validation, and optimization of products and manufacturing tools. In the future, CAE systems will be major providers of information to help support design teams in decision making.

## **CHARACTERISTICS OF GOOD SOFTWARE**

The characteristics of good software are enumerated below thus:

- i. **Efficiency:** The program must result in the effective use of the Central Processing Unit (CPU) in terms of both time and storage. It may be costly to develop, and it is also related to the size or complexity. A well designed small program may be more efficient than a large complex one.
- ii. **Simplicity:** Must be very easy to use or user-friendly.
- iii. **Flexibility:** This is the measure of degree of difficulty involved in modifying software to conform to a new specification.
  - Properly designed software will easily be amenable to future modifications ore changes.
  - Flexible software requires little maintenance.
- iv. **Readability:** This is a measure of how easily user can comprehend the logic behind the software.

- Requires proper documentation of the programming process within the program
- Style and aesthetics are important: helpful to less much space as possible between various parts of the program.
- v. **Portability:** Deals with transfer of a program from one system to another; very desirable in CAD.
  - Most applications programs so far in CAD are machine dependent.
- vi. **Reliability:** Measure of the functionality of the software with respect to desired specifications.
  - Very important aspect of software design, especially many processes/operations that are software dependent deal with human life.
- vii. **Recoverability:** Must not crash owing to an error made by user. Entry data error must have some way of warning the user and continue to function. This is recoverability of software. Recovery from error.

### SOFTWARE COMPONENTS

The software components are divided into three parts:

- i. Data;
- ii. Algorithm; and
- iii. Structure.

**Data:** are raw, unprocessed facts that are input to a computer system. It can also be set whose members or elements are numerical values, names symbol and codes.

**Algorithm:** show how a set of data should be manipulated

**Structure:** is the organisation of software

Good software provides a good organisation of data algorithm.

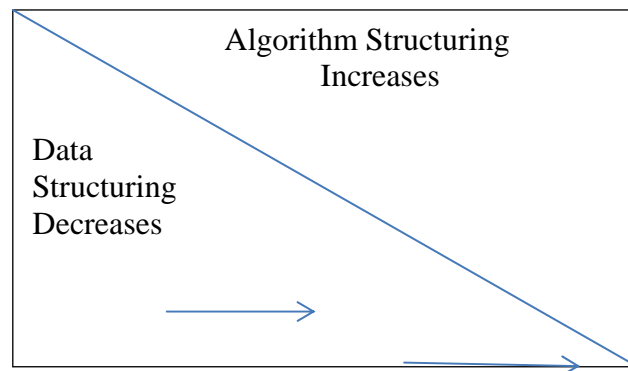

Fig. 5.1: Shows that properly structured data-less structuring of algorithm and vice-versa

### DATA STRUCTURE

Organisation of data elements such as to both maintain the logical assembly and relationship between them and provide access from one data element to another. Each data element may be one of 3 types: integer, real or logical.

Integer data: elements have integer numerical values: data elements of the real type consist of numerical value that includes decimal parts. Logical type data elements have logical values of "TRUE" and "FALSE".

**Classification:** There are fixed or constant and variable structure in fixed structures, relationship between data element in invariant whereas in variable structures, the relationship between data elements is subject to change.

**Fixed Data Structures**

There are four types of fixed data structure,

(a) Vectors: Vector is a data structure with the same type of data elements e.g. the data elements are either all real numbers or all logical values. The size of a vector is determined by the number of elements it contains. The elements can be accessed through an index usually a positive integer associated with it. This is shown in fig. 5.2 below thus:

Index	Elements
1	5
2	210
3	1000
4	355
5	628

Fig. 5.2: Identification of Vector Elements.

For example, the number 1000 can be accessed through the index number 3. If the programming language is FORTRAN, this number can easily be called or assigned to another entity as shown in Fig. 5.3 below thus;

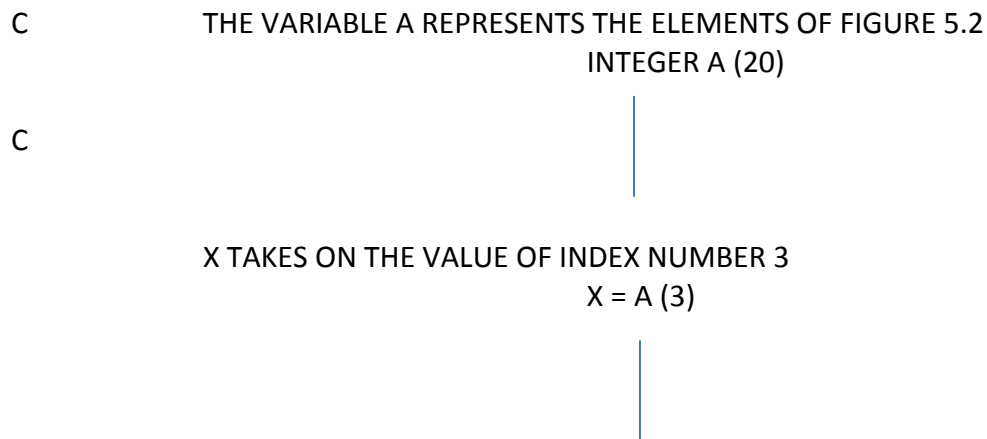

FIG. 5.3 Assignment of array – element to another variable

(b) Array: An array is a set consisting of a fixed number of the same type of data elements. If an array is 1-D then there is no difference between an array between a vector.

Vector is a 1D array. An n-D array can be brought of as a collection of vectors. The elements of an array are referenced by an ordered set of indexes. The index used depends on the dimension of the array, e.g. a 2D array requires a set of 2-index values. The limit to the



form and then change the angles, when necessary. Rotation can be accomplished using the matrix given by

$$[X^1 Y^1 1] = [X Y 1] \begin{bmatrix} \cos\theta & \sin\theta & 0 \\ -\sin\theta & \cos\theta & 0 \\ 0 & 0 & 1 \end{bmatrix}$$

The rotation matrix is a 2D array, and if all the 9 elements, only 4 of them will actually change as the rotation is performed through various angle.

(c) **Strings:** A string is a sequence of characters (alphabetical or numeric) or symbols. In FORTRAN, a string is characterized by single quotes- for example "CHEM" or "4234"- but some FORTRAN compilers requires the use of double quotation marks.

\$. The use of strings is the processing of nonnumerical data. It is particularly useful in the development of interactive programs, for example, in BASIC, if you want a response in order to decide what course of action to take, a string such as the following may be used.

100 INPUT A \$



900 IF A \$ = "YES" THEN 910 ELSE 2000

(d) **Record:** It is an ordered set of different data elements. Organizing and collection of arrays by using a record. It allows data to be represented as a tree, such as:

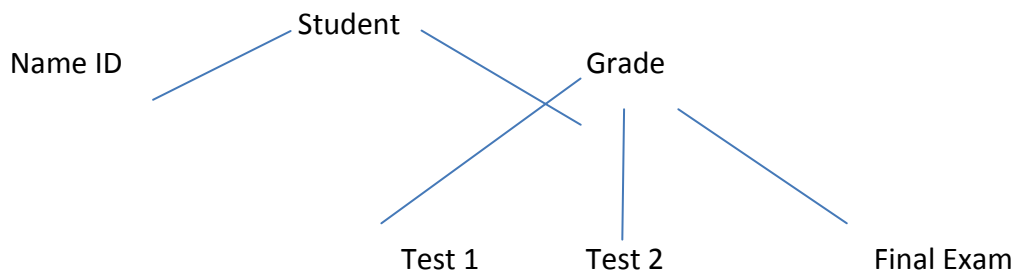

FORTRAN provides for the use of arrays but does not directly provide for the use of records. The programmer must construct records for simple data array structures by defining the individual components of the record. For example, suppose a record of student is to be kept, using an ID number as shown.

ID No	Grade %
1	83
2	60
3	75

A record data structure may be created in FORTRAN using the program given as:

```

C    A RECORD OF GRADES FOR STUDENTS IN A CLASS
C
C    CLASS SIZE 15 35
        REAL GRADE (35)
        DO 2 1 = 1, 35
        READ, GRADE (I)
        2 CONTINUE

```

### Variables Structures

There four different types of variable structures are:

- List;
- Stock;
- Queue; and
- File

Enumerate it one by one gives;

- (a) List: A 10 data structure consisting of an assemblage by elements; it is one of two forms:
- (i) Linear; or
  - (ii) Linked
- (i) A Linear List: is made of element whose adjacent members are contiguous (Fig 5.4). It is similar to a vector, except that a linear list allows addition or deletion of elements and it need not be homogenous.
- (ii) A Linked List: is a list in which each list element has a pointer to its successor. Usually, a special pointer are used to mark the head of the list and the end of the list is marked by a pointer whose value is a null (empty, Fig. 5.5)

The link in a linked list may be useful to establish and desired logical order for the data elements without changing the physical order of the elements (Fig. 5.5). For example, suppose an array A contains some data and the contents are not to be printed sequentially, the order of points is to be dictated. The linked list structure to perform the job is shown in Fig. 5.5 and a sample program follows.

Cube	Cylinder	Sphere	Cone
------	----------	--------	------

**Fig. 5.4: A linear list of geometric primitives.**

Index

Printed order

The program:

- Portion of program illustrating the use of linked list,
- Assuming that array A and link exist

```

ORDER = 1
30    CONTINUE
      IF (ORDER, NE O) THEN
      WRITE (6, 40) A (ORDER)
40    FORMAT (20 X 1 4)
      ORDER = LINK (ORDER)
      GO TO 30
      ELSE GO TO 100
      END IF
100   CONTINUE

```

(b) **Stack:** A stack is a linear list accessible only at one end with addition/election taking place at the accessible end. Alternate name for stack list is LIFO (acronym for last-in-first-out), for example, warehouse where plywood boards are placed in stacks, the 1<sup>st</sup> to be removed is the last board placed.

There are two main types of manipulation of stack:

- Pushing and popping

Pushing – is the process of adding an element to the stack.

Popping – is the process of deleting element from stack.

Stack data structure is useful for processes where there is an interruption of main task for a sub stack and consequent return to the main: this is called a subroutine. Stacks are also used for arithmetic operations.

(c) **Queue:** A queue is a linear list that can be accessible at two locations. Insertion can be performed only on one end (rear), while deletion is carried out on the other end (font). And another name for queue is FIFO (acronym for first-in-first-out).

It is useful for operation where information is processed in the order in which it is received; it has many applications in operating systems where jobs are queue until an execution slot can be found for the queued jobs.

(d) **Files:** A file is a list (or an array) of records. It may involve 100's or over 1000's of storage units require large storage space; hence stored in secondary (external) storage devices such as magnetic tapes and disk. It is called to main memory when processing.

It needs to access files since they are in external memory in FORTRAN, two access methods are possible sequential and direct.

Sequential: Permits only orderly retrievals of records in a file.

Direct: allows random access of records in a file. They are stored in magnetic disks where the records are arranged in an arbitrary order.

READ and WRITE FORTRAN struts are used to transfer data from external memory to the main memory of the computer and vice versa.



## **NC, CNC, DNC, AUTOMATION, ROBOTICS, CIM, ARTIFICIAL INTELLIGENCE AND EXPERT SYSTEMS**

This topic focuses on the following new technologies of manufacturing systems:

- Numerical Control Machine Tools (NC);
- Computer Numerical Control Machine Tools (CNC);
- Direct Numerical Control Machine Tools (DNC);
- Robotics;
- Computer Integrated Manufacturing (CIM);
- Artificial Intelligence; and
- Expert Systems.

The trend in manufacturing call for the development of the following modern day manufacturing systems. There are:

- Global competition in the manufacturing market;
- Customers now demanded high-quality goods, with low production cost and timely delivery of manufacturing products.
- Increase in the variety of products produced, thereby choosing the product life cycles to be shorter.

Therefore, the modern day technology that manufacturing systems make use of are discussed in this chapter.

Manufacturing system entails a large number of interdependent activities consisting of distinct entities such as materials, Tools machines, power, and human beings. It is a complex system because it is comprised of many diverse physical and, human elements. The choice are many, so the manufacturing engineers should be able to select correct which one to choose, that will profit the whole manufacturing system.

### **MANUFACTURING CYCLE**

Manufacturing is a dominant activity in an individual organization. Before areas of computer needs are established, the need to understand the manufacturing process it self.

Like design, there is no unique process for manufacturing. It all depend on products to be manufactured. For example, we have manufacturing industry, tyre, fuel/chemical products, machines tools, heavy vehicles such as earth moving equipment for farming and road construction, food processing, canning/bottling plants such as breweries, foundries, etc. each has its manufacturing process with diversification within each group as in the case of processed adopted by different company's in the same industry.

Nevertheless, there are some general processes that would need manufacturing as an activity that shares an interface with engineering design. It is an engineering activity in Fig. 13.1. shows a typical manufacturing cycle.

As in design, the manufacturing process begins with a set of objectives which are set by management. Such objectives may be;

- (i) To develop and fabricate product;
- (ii) To produce parts or products designated by the customer/client
- (iii) To reproduce items that has been manufactured in the plant.

Manufacturing environment can differ with respect to;

- (i) Size of the plant;
- (ii) Type of industry; and
- (iii) Type of production.

Regardless of manufacturing environment, the fundamental principles are the same for all manufacturing concerns, hence a general cycle can be formulated in Fig. 13.1

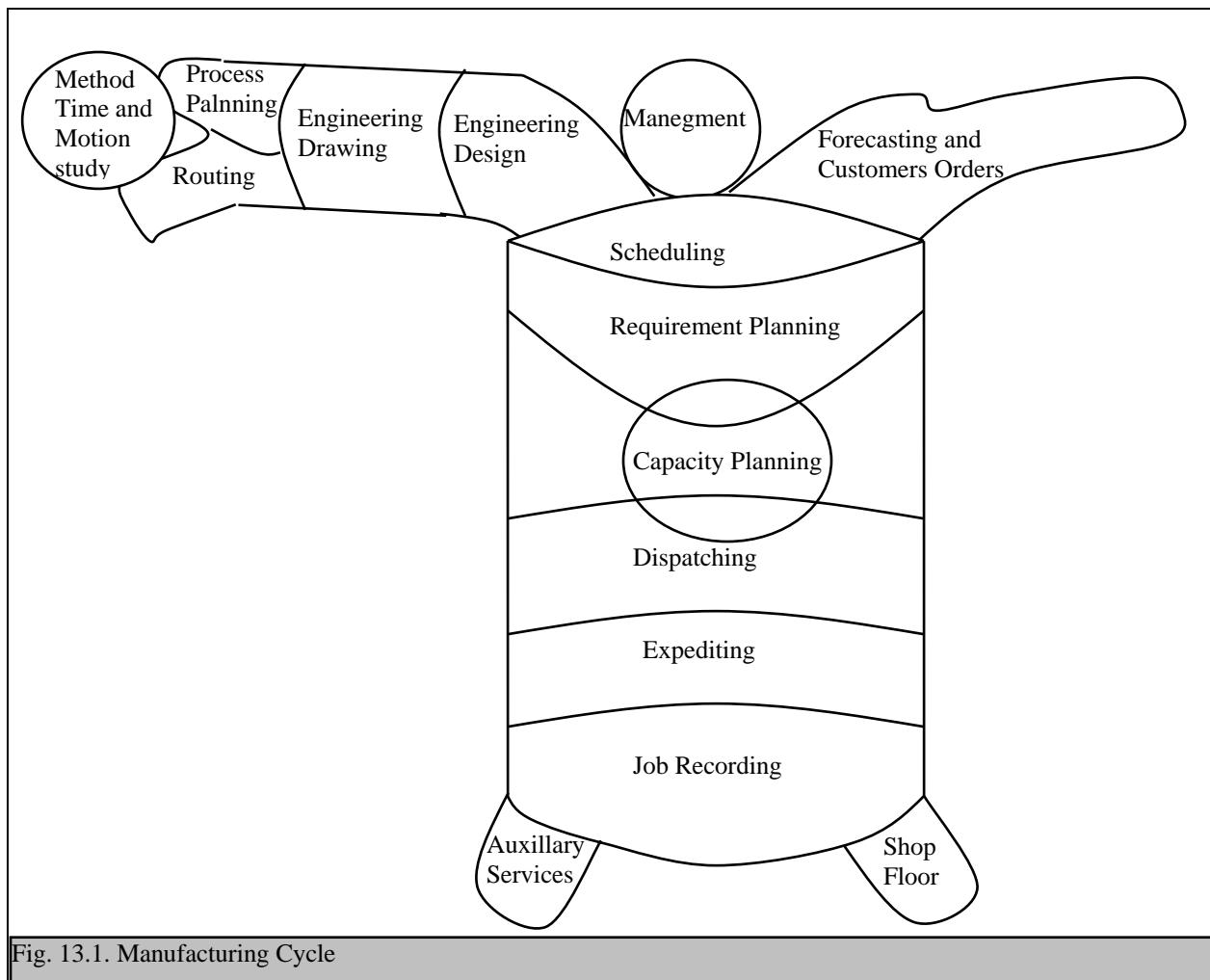

Fig. 13.1. Manufacturing Cycle

Emphasis varies with respect to mode of manufacturer's specific problems, for example, mass production; emphasis would be on process planning and methods.

Auxiliary production aids such as special tools and machinery, jigs and fixtures are automatic inspection services should be designed, produced and used. Material Requirements Planning and Scheduling need not to be sophisticated; therefore, rate of production is limited as fixed by initial design.

For production of the large-scale job-shop type, where several orders are to be produced in small quantities and only once, emphasis would be on scheduling. In small-size jobs specializing in producing parts designed by customers, the engineering phase may not be required at all (except for customer consultation and advice). In goods type industry. Emphasis is on engineering design phase.

Fig. 13. 1 shows the different types of phases of activities involved in a manufacturing cycle. Each phase consists of a continuous chain of activities. Notice that engineering design and engineering drafting are processes in the manufacturing cycle. CAD is involved in these processes. Similarly, computer aids are required in all the other phases. All amount to CAM. The challenge of CAM is the interface programs to link all the processes in the cycle computer software are available for most of the processes and they are independent of one another. To integrate all the processes constitutes the Integrated manufacturing System (IMS).

### **Numerical Control (NC), Computer Numerical Control (CNC), Direct Numerical Control (DNC), Automation and Robotics**

The introduction of NC, CNC, DNC, Automation and robotics is the beginning of CAD/CAM. The automation witnessed in manufacturing is a result of the development is a result of the development of the following machines which will be discussed in this section.

#### **Numerical Control (NC) Machines**

Numerical Control (NC) can be defined as a form of programmable automation in which the process is controlled by numbers, letters and symbols. In NC, the numbers form programme of instructions designed for a particular work part or job. When the job changes the programme of instruction also changes.

Numerical Control (NC) is an automated method used to operate general purpose machines from instructions stored on a roll of tape for future as well as present use. The method can be used with or without a computer. Numerical Control (NC) is just what the term implies- control by the numbers. The two words “control” and “numbers” have brought about a revolution in manufacturing.

NC technology has been applied to a wide variety of operations, including drafting, assembly, inspections, sheet metal press working and spot welding. However, NC found its principal applications in metal machining process.

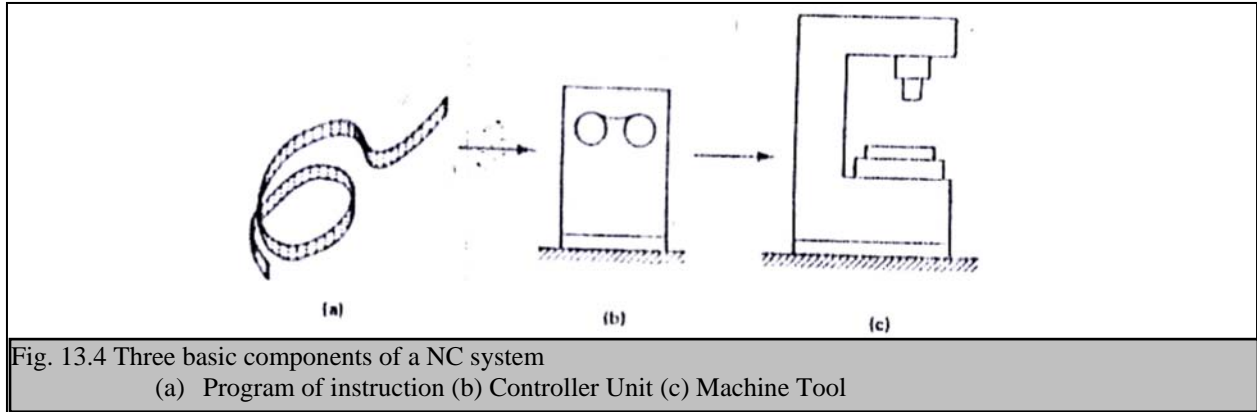

An operational NC system consists of three basic components. Thus,

- Program of instruction;
- Controller unit of machine control unit;
- Machine tool or other controlled process.

### How an NC System Operates

NC system falls into two categories thus;

- Open Loop; and
- Closed Loop.

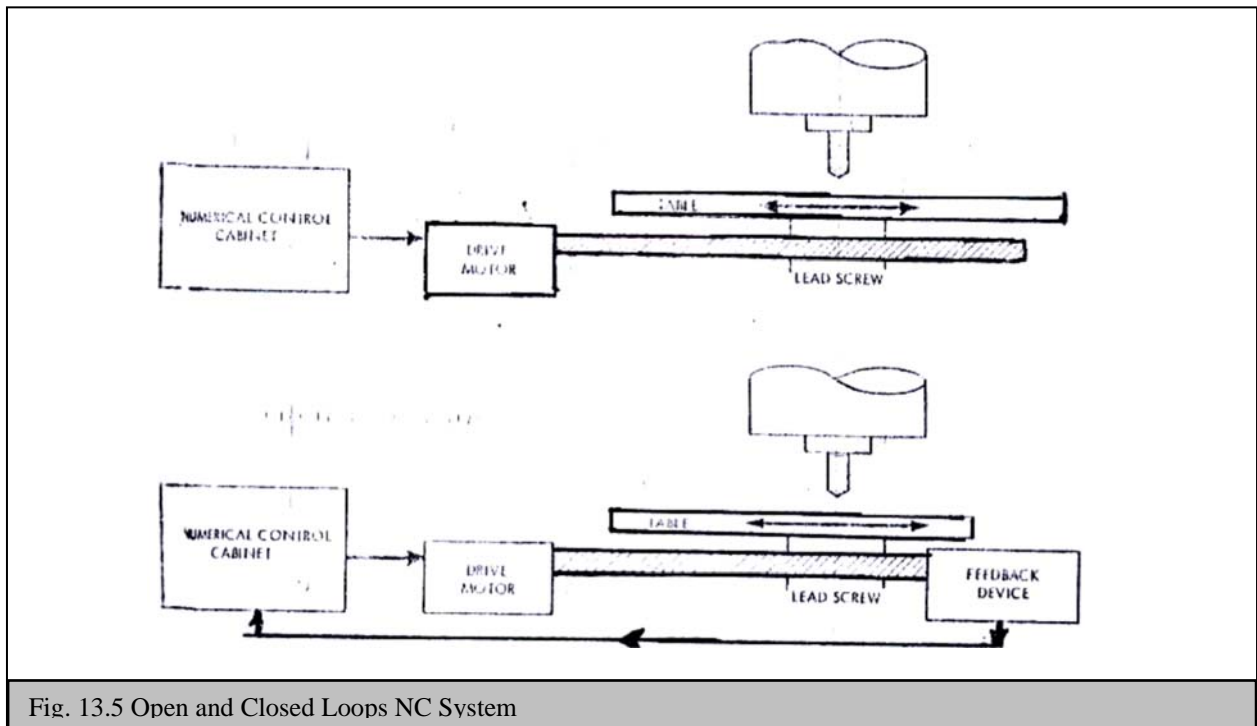

Open- loop Fig. 13.5 above shows an open- loop NC system when a signal or command is given to the machine tool in order to carry out specific operation, and the tool more to its ordered

position, and the tool stop, and there is no feed back as to if the assignment has been done, then this system is considered or referred to as open- loop.

Closed- Loop Fig. 13.5 shows a closed loop NC system. When a signal or command is given to the machine tool in order to carry out specific operation and there is feedback built into the system, this is known as a closed- loop NC system.

In general, a closed loop system will be more expensive to apply to machine tool control than an open loop system.

### Types of NC

There are two types of NC systems;

- (i) The positioning or Point to Point System,.  
It is used to control machine tools like;
  - Drill press; and
  - Jig borer.

This type of machine performed operations only at specialised points on a work piece.

- (ii) The Construction Path System.

This type of machine removes metal continuously from surface of a workpiece.

### The NC Procedure

To utilise Numerical Control (NC) in manufacturing, the following steps need be accomplished;

- (i) **Process Planning:** The engineering drawing of the work part must be interpreted in terms of the manufacturing processes to be used and it deals with sequence of operations.
- (ii) **Part Programming:** A part programmer plans the process for the portion of the job to be accomplished by NC. The program of instructions is the detailed step by step set of directions, which tell the machine tool what to do. There are two ways to programme for NC.
  - **Manual Part Programming or Manual Data Input (MDI):** used for sample jobs.
  - **Computer- Assisted Part Programming or Direct Numerical Control (DNC).**
- (iii) **Tape Preparation:** This is a punched tape, which is prepared by part programmers of NC process plan.
- (iv) **Tape Verification:** This is a method of checking the already prepared punched tapes for accuracy.
- (v) **Production:** This is where the NC tape is used for the production of the component

### Measuring Basic for NC System- Axes System

The basic for this part programmer to plan the sequence of positions and movements of the cutting tool relative to the work piece is the system of rectangular coordinates.

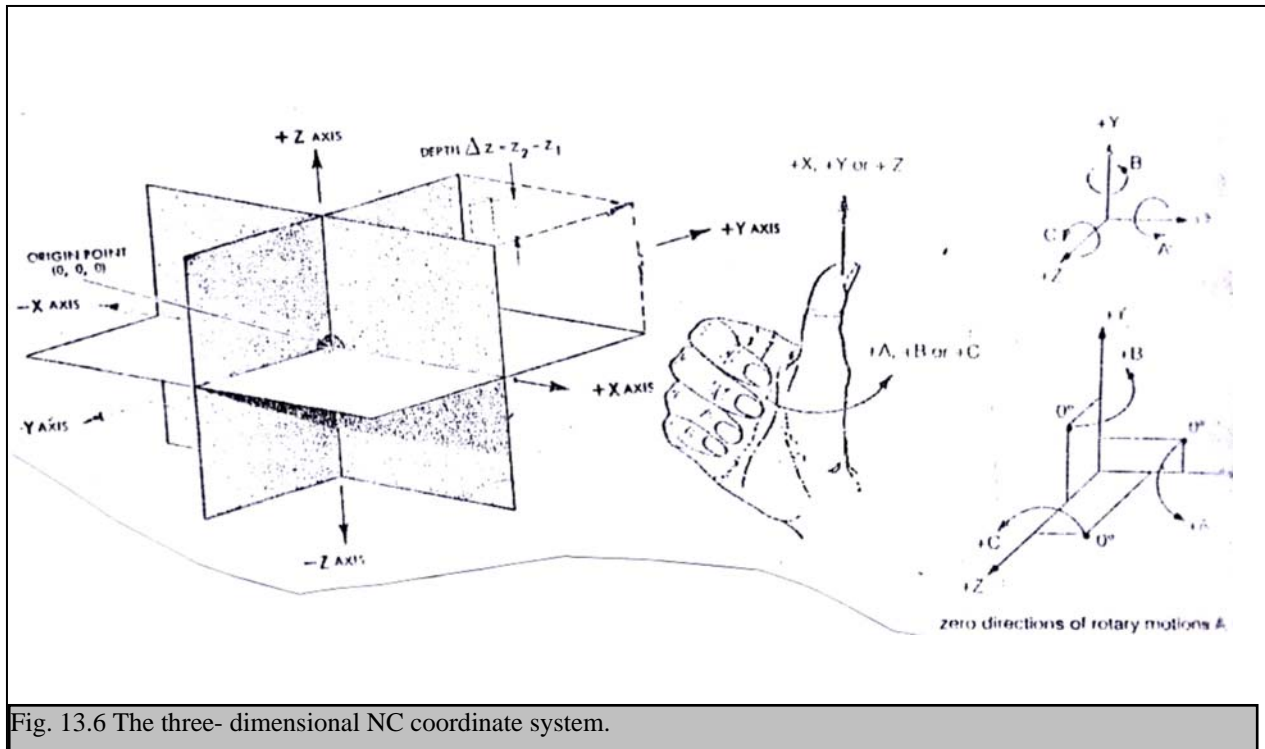

Fig. 13.6 The three- dimensional NC coordinate system.

Fig. 13.6 above shows the Cartesian coordinate system, all point positions are described in terms of distances from a common point called the margin and measured along certain mutually perpendicular dimension lines called axes. It is necessary to locate every point called the X, Y, and Z axis.

### Ordinate Calculating and Planning

The component drawing to be machined is shown in Fig. 13.7 (a) below thus;

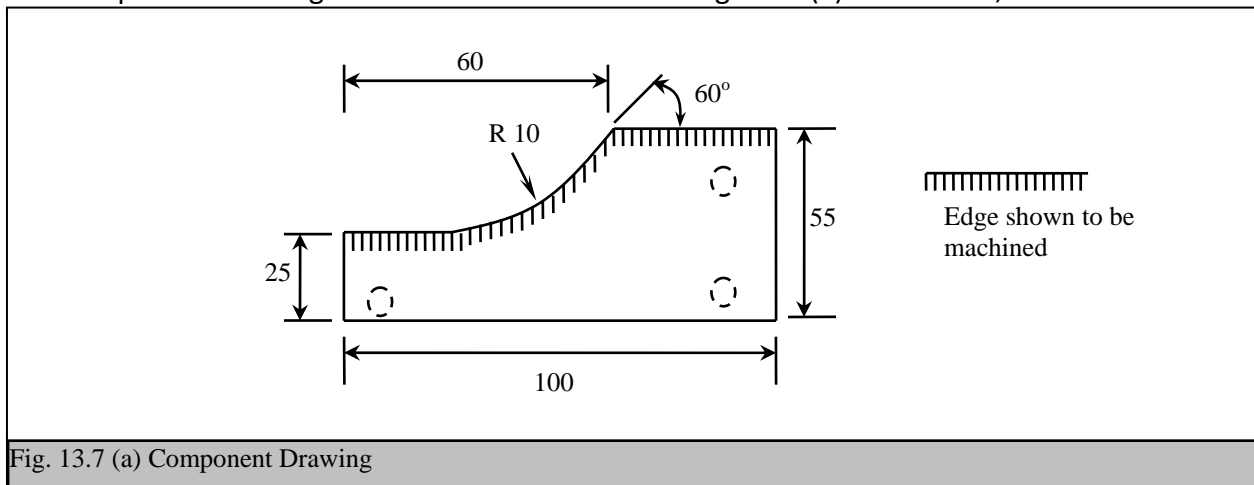

Fig. 13.7 (a) Component Drawing

Then draw the ordinate drawing as shown in Fig. 13.7 (b) below thus;

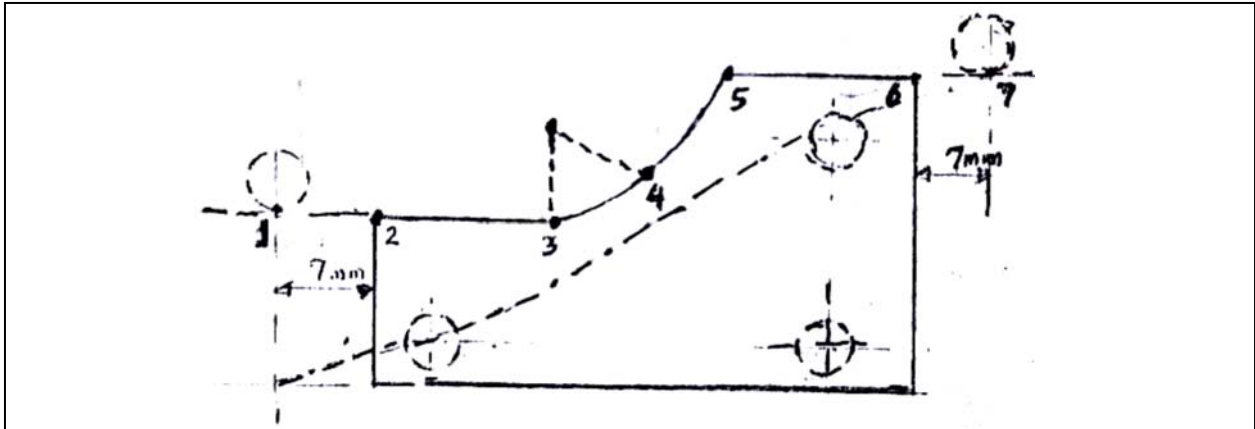

Fig. 13.7 Ordinate Drawing

Draw data in point ( and cutter setting point)

Table 13.1 Ordinate Tables

Point	Co=Ordinates from datum point (←) Xmm (→)	
1	0	+25.0
2	+7.0	25.0
3	+40.0	25.0
4	+50.0	+30.0
5	+67.0	+55.0
6	+107.0	55.0
7	+114.0	55.0

The co- ordinates shown are calculated from the datum to the work profile. The co-ordinates are calculated from the datum to the cutter centre.

It is possible to write out all the above ordinate information on to a planning sheet or programme. The programming used can be;

- Recording the ordinate information on paper tape; and
- Planning information on the same tape.

### Advantages and Disadvantages of NC

The advantages of NC are stated thus;

- Reduced non productive time;
- Reduced manufacturing lead time;
- Greater manufacturing flexibility;
- Improved quality control;
- Reduced inventory; and reduced floor space requirement.

The disadvantages of NC are;

- Higher investment cost;
- Higher maintenance cost; and
- Funding and or training of NC personnel.

## COMPUTER NUMERICAL CONTROL (CNC)

Computer Numerical Control (CNC) is a NC system that utilizes a dedicated, stored programme computer to perform some or all of the basic NC functions. The NC machines have progressively developed into the multi-axis, multi-tooled and highly efficient CNC machines of today. Most of the CNC systems users micro computer based controlled.

### Principles of CNC Machines

Many machines used in manufacturing uses CNC control systems.

It may be categorised thus;

- Metal cutting (lathes, milling machines etc.);
- Metal forming (bending and folding machines, etc.);
- Metal joining ( welding machines); and
- Component inspection ( Co-ordinate inspection machines)

Compared to regular NC, CNC offers additional flexibility and computational capability. New system options can be incorporated into the CNC controller simply by reprogramming the unit. CNC is often referred to by the term “software NC”.

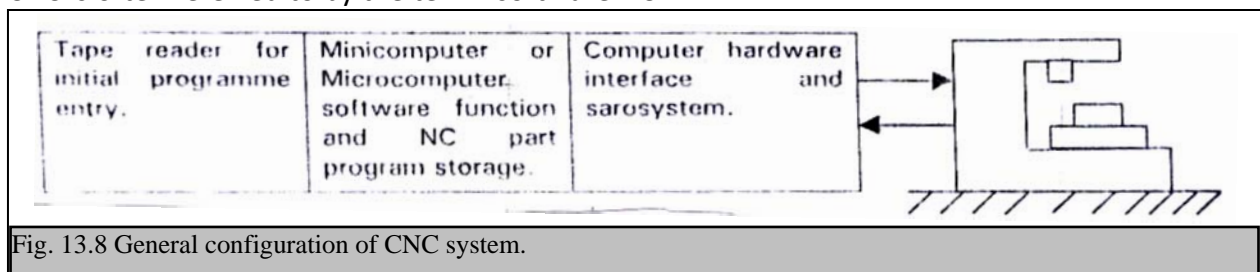

Fig. 13.8 General configuration of CNC system.

The functions of CNC, which can be difficult for NC, are;

- Machine Tool Control:** This is the process of converting the part program instruction to machine tool motion using computer interface and series system
- In- Process Compensation:** This is the process of the dynamic correction of the machine tool motion for charges or errors which occur during processing.
- Improved Programming and Operating Features:** There are improved programming and operating features., such as Editing at part at the machine graphic display various types on interpolation etc.
- Diagnostics:** CNC are required with diagnostics capacity to assist in maintaining and repairing system.

### Advantages of CNC

CNC has some inherent advantages over NC. Some are enumerated below thus;

- The use of part program tape and tape recorded once to enter the program into computer memory.
- The tape can be edited at the machine site.
- It has the ability to convert all other units to metric system.
- It has a greater flexibility,



- Users can generate his own program, that is, user written programme.
- Total manufacturing system.

### DIRECT NUMERICAL CONTROL (DNC)

The Direct Numerical Control (DNC) can be defined as a manufacturing system in which a number of machines are controlled by a computer through direct connection and in real time. The DNC are not making use of tape reader like NC machines. It used part programs which are transmitted to the machine tool directly from the computer memory. It is possible to use one computer to control more than 100 separate machines. It will provide instructions to each machine tool on demand. The control commands can be communicated to the machine immediately the machine is of used or to it. The DNC machine consists of four components thus;

- Central computer;
- Bulk memory, which stores the NC part programs;
- Telecommunication lines; and
- Machine tools.

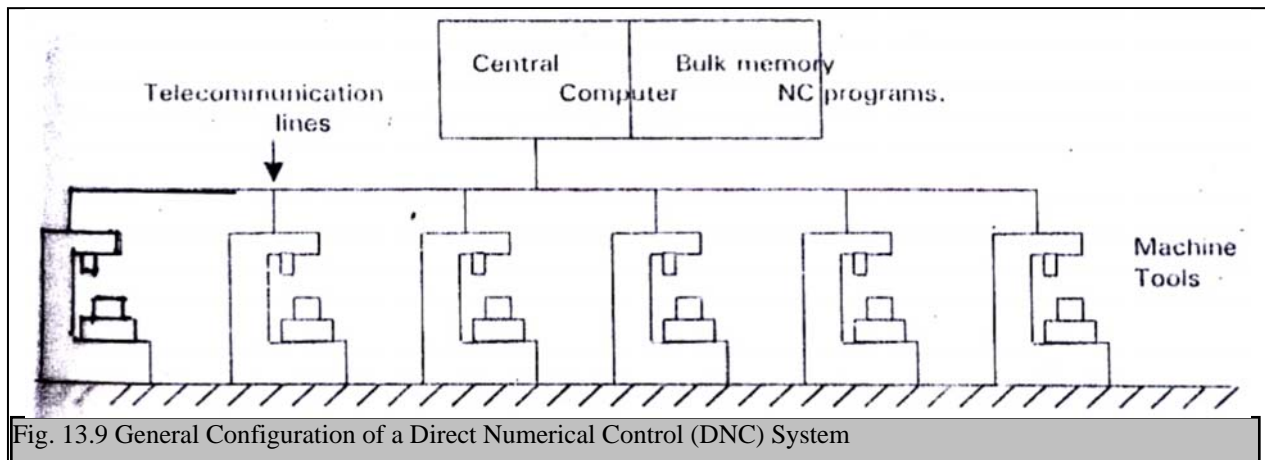

Fig. 13.9 General Configuration of a Direct Numerical Control (DNC) System

### Fig. 13.9 General Configuration of a Direct Numerical Control (DNC) System

The fig. 13.9 above shows the general configuration of direct Numerical Numerical (DNC) systems. The computer calls the part of program instruction from the bulk memory NC programs and sends them to the individual machines as each machine demanded for it. It is also possible to receive data back from the machine using the same route.

If the machines needed are many, it is possible to use satellite computers, which are smaller computers. Which take some of the burdens of the larger central computer?

The satellite receives information from the central computer and controls several machines. The information received from the central computer by the satellite mini computer are stored in the memory buffer, which can be used by each machine. Fig. 13.10 shows the DNC in hierarchical configuration using satellite computers.

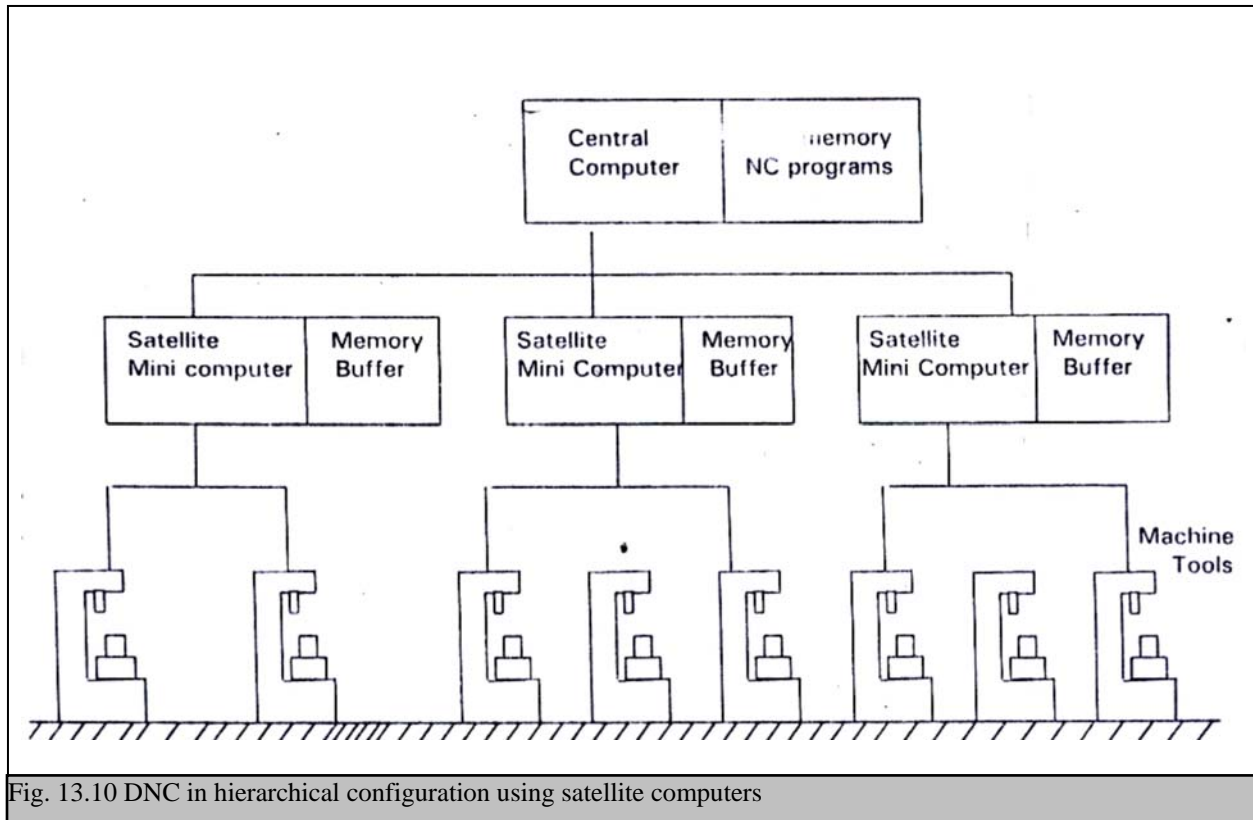

Fig. 13.10 DNC in hierarchical configuration using satellite computers

There are two major types of DNC they are:

- (i) Behind the Tape Reader (BTR) systems; and
- (ii) Special Machine Control unit.

### ADVANTAGES OF DNC

Some of the advantages of DNC machine includes;

- (i) Time sharing;
- (ii) It has a greater computational capability
- (iii) It is located in a computer type environment;
- (iv) It eliminate tapes and tape reader, which improved reliability.
- (v) It is possible to post-processed the programs stored as cutter location data for any machine that is assigned to process the job.
- (vi) It eliminate hard wire controller unit on some systems.

### AUTOMATION

Automation is a technology concerned with the application of mechanical electronic, and computer-based systems to operate and control production. This technology includes;

- Automation machine tools to process parts;
- Automation assembly machine
- Industrial robots;
- Automatic material handling and storage systems;

- Automatic inspection system for quality control;
- Feedback control and computer process control;
- Computer systems for planning, data collection and decision making to support manufacturing activities.

### Types of Automation

There are three major types of automation viz;

- (i) Fixed automation: In a system in which the sequence of processing or assembly operation is fixed by the equipment configuration.
- (ii) Programmable automation: The production equipment is design with the capability to change the sequence of operation to accommodation different product configurations.
- (iii) Flexible automation: Is an extension of programmable automation. Is capable of producing variety of products changeover from one product to the next.

### ROBOTICS

There are several definition of an individual robot, some of them are reviewed below;

- Is a reprogrammable multi-functional manipulator designed to move materials, parts, tools, or specify devices through variables programmed motions for the performance of a variety of tastes.
- A re-programmable, multifunctional manipulator
- Is a manipulating device that is both versatile and also easily programmed for re-programmed to perform a sequence of operations.
- A general-purpose, programmable machine possessing certain anthropomorphic characteristics.

### Robot Sub-systems

The combination of several different modern technologies into one machine is the attributes of an individual robot. Microelectronics, electric motors, fluid power systems, sensor technology and mechanical transmission are the basic development in robot, which has contributed to its versatility and accuracy, fig 13.11 below shows the main sub systems that make up a modern day robot.

The most typical anthropomorphic or human-like characteristics of a robot is its arm. The arm with its whole body can be programmed to carry out a specific production tasks, like machine loading, spot welding, spray painting, and assembly.

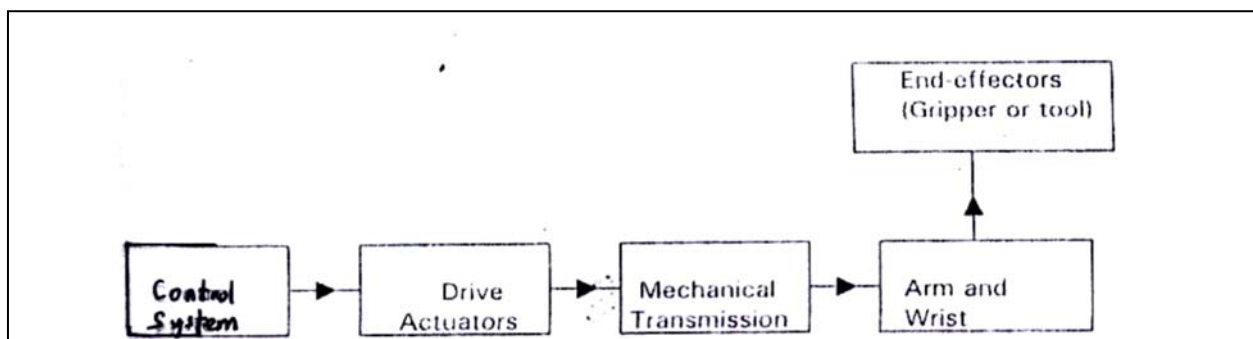

Fig. 13.11 Robot Subsystems

## **Robot Anatomy**

The manipulation of an individual robot is constructed of a series of joints and links. Robot anatomy deals with the types and sizes of the joints and links and other aspects of the manipulators physical construction.

Joints and Links: there are different types of joints and links in use, some of their uses are

- Linear joint;
- Orthogonal joint;
- Rotational joint;
- Twisting joint; and
- Revolving joint.

To establish the position of an object, the body and arm must be capable of moving the object in;

- Vertical motion (z-axis motion)
- Radial motion (in-and out or y-axis motion)
- Right to left motion (x-axis motion or swivel about a vertical axis on the base)

### (iii) Common Robot Configuration

There are five common configuration they are:

- Polar configuration;
- Cylindrical configuration;
- Cartesian coordinate robot;
- Jointed-arm robot; and
- Selective Compliance Assembly Robot Arm (SCARA)

## **Robot Control Systems**

The joint and links discussed in 6.5.2 must be controlled, so that it can perform to a desired level. Therefore, the drive systems and the control system used in robotic are;

### (i) Drive systems

Some of the drive systems used in robotics are: electric drive, hydraulic drive, and pneumatic drive. Electric drives are more active and are readily adaptable to computer control. It is predominantly used today for robot controllers.

### (ii) Type of Robot Control

Some of the types of robot controller can classified into:

- Limited sequence robot;
- Play back robot with point-to-point control;
- Play back robot with continuous-path control; and
- Intelligent robots.

## **Benefits of Robots**

The benefits derived for introducing robot are;

- (i) Overcoming environmental hazards problems;
- (ii) Increased productivity;
- (iii) Improved quality; and
- (iv) Operational flexibility.

## **COMPUTER INTEGRATED MANUFACTURING (CIM)**

Computer Integrated Manufacturing (CIM) system is primarily concerned with the integration and management of the total manufacturing process. It is a system that recognise and supplies computer services to each phase of the manufacturing cycle independently, while at the same time maintaining a database that serves a single source of data for all company activities and applications.

The term Computer-Integrated Manufacturing (CIM) is often used interchangeably with Computer-Aided Design and Computer-Aided Manufacturing (CAD/CAM). Although the terms are closely related, CIM is interpreted to possess a slightly broader meaning and in scope than CAD/CAM.

Computer-Integrated Manufacturing (CIM) includes all the engineering function of CAD/CAM, but also includes the business function of applies technology for all of the operational function and information processing functions in manufacturing from order receipt, through design and production to product shipment and service and field support after sales. The scope of CIM and computerized element of the CIM system is as shown in (Fig. 13.12 and 13.13)

The CIM concept is that all of the films operations related to production function are incorporated in an integrated computer system to assist argument and or automate the operations. It touches all the activities that support manufacturing, with the output of the activity serving as the input to the next activity through the chains of events that starts with the sales order and end with shipment of product.

Customer orders are initially entered by the company's sales force into computerised order entry systems. The orders contain the specifications describing the products. The specification serves as the input to the product design department.

One of the most daunting challenges in Computer Aided design (CAD) and Computer Aided Manufacturing (CAM). Many specific approaches have been developed for limited manufacturing domains, for example, a solid model may be directly converted into Numerical Control (NC) code for a computerized milling machine. But when we try to extend the planning to cover a number of domains, there are no satisfactory techniques. These still leaves many unresolved problems when converting a product from design features to manufacturing features.

Computer Integrated Manufacturing (CIM) is a term used to describe a facility for manufacturing a variety of products using computers to initiate, control and monitor the activities. It is very difficult in reality to have completely automated facilities anywhere in the world. But each company is progressing in obtaining this total CIM.

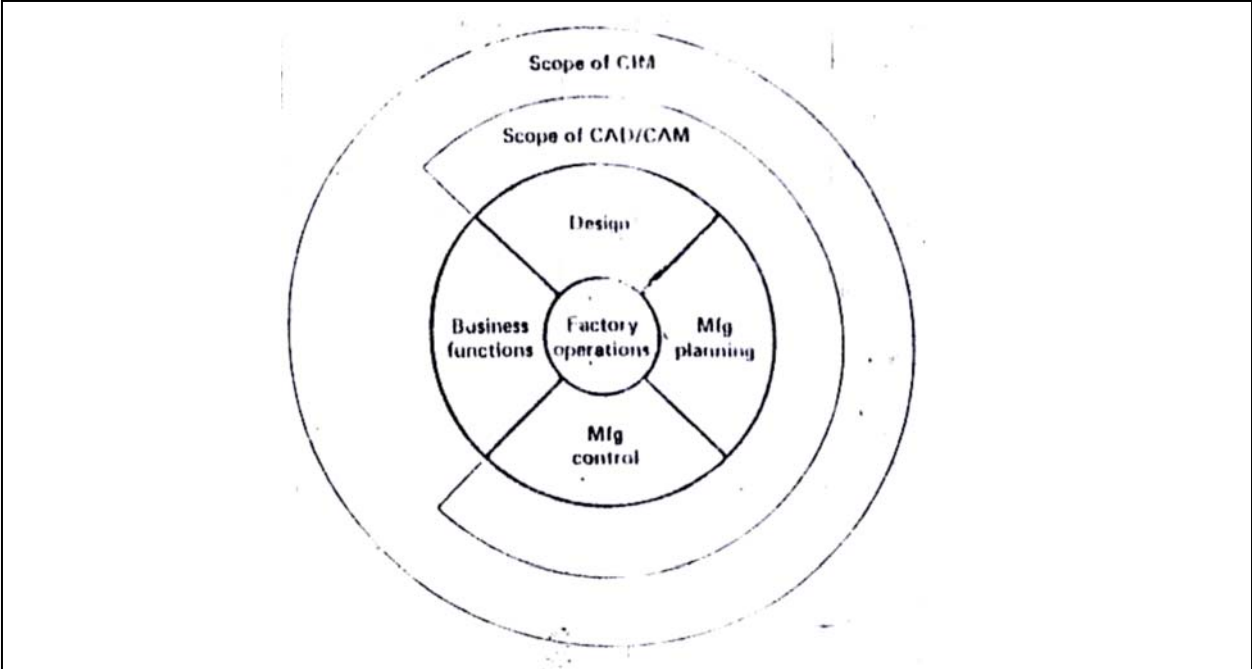

Fig. 13.12 Scope of CAD/CAM and CIM

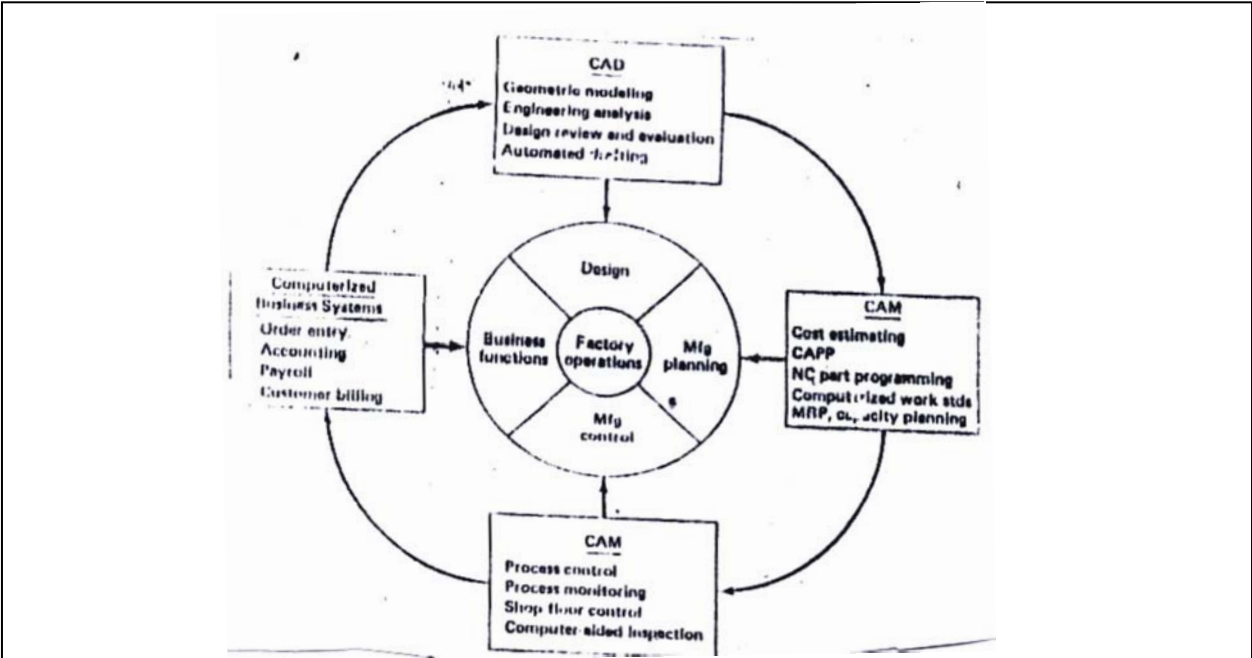

Fig. 13.13 Computerized element of a CIM system

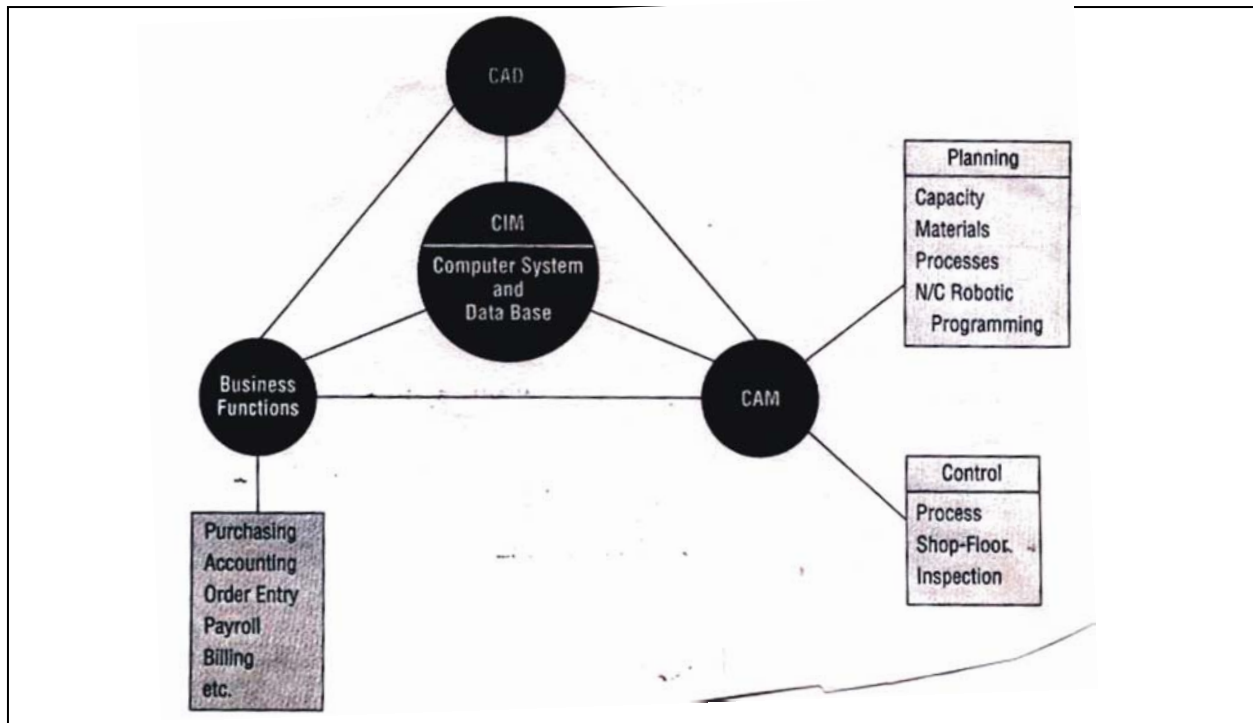

Fig. 13.14 A schematic illustration of a CIM system

Fig. 13.14 above shows a schematic illustration of Computer-Integrated Manufacturing systems. It consists of a lot of sub-systems that are integrated into a whole. The subsystems are

- Business planning and support,
- Product design;
- Manufacturing process planning,
- Process control;
- Shop floor monitoring systems; and
- Process automation.

The subsystems are designed, developed, and applied in such a manner that the output of one subsystem serves as the input of another subsystem.

### THE SCOPE OF CIM

The Computer-Integrated Manufacturing (CIM) incorporate many of the individual CAD/CAM technologies and concepts which is the basic concept of this book. The technologies which have been discussed are;

- (i) Computer-Aided Design (CAD)
- (ii) Computer-Aided Manufacturing (CAM)- Planning; and
- (iii) Computer-Aided Manufacturing (CAM)- Control;

The fourth one which is not in the scope of CAD/CAM technologies and are in the CIM is Computerized Business System. The scope are discussed below thus;

### Computer-Aided Design (CAD)

This is originally a design phase (Fig. 12.1) but when computer is added in involve the following operations;

- Geometric modelling;
- Engineering Analysis;
- Design Review and Evaluation; and
- Automated Drafting.

### **Computer-Aided Manufacturing (CAM)-Manufacturing Planning**

This is the area of manufacturing control. It involves;

- Cost estimating
- Computer-Aided Process Planning (CAPP)
- Numerical Control (NC) Part Programming;
- Computerized work studies
- Material Requirement Planning (MRP); and
- Capacity Planning.

### **Computer-Aided Manufacturing (CAM)- Manufacturing Control**

This is the area of manufacturing planning. It involves;

- Process Control;
- Process Monitoring;
- Shop Floor Control; and
- Computer-Aided –Inspection.

### **Computerized Business Systems**

The major business functions that involve CIM are;

- Order Entry;
- Accounting
- Customer billing.

The business functions are the principal means of communicating with customer. They are therefore, the beginning and the end of the information-processing cycle include within the category are sales and marketing, sales forecasting, order entry, cost accounting, customer bailing and others.

An order to produce a product will typically originate from the sales and marketing department of the firm. The production order will be one of the following;

- (i) An order to manufacture an item to the customer's specifications
- (ii) A customer order to buy one or more of the manufacturers proprietary product or
- (iii) An order based on a forecast of future demands for proprietary products

Accounting departments keeps track of all financial activities. It pays bills, records payments, issues pay checks, and complies periodic financial statements. This department performs two major activities.

- It records bills and other financial transactions with sporting goods stores and produces financial statements.
- It products financial budgets and forecasts of projected financial performance to help managers run the business.

### **TECHNIQUES EMPLOYED IN CIM**

Some techniques are used in CIM, which is used in manufacturing situation. Some are;

- Database



- The database is the heart of the CIM system, since it receives, possesses and outputs information/data needed for all manufacturing and administration functions. You can read more about database system in chapter three of this book.
- Interfacing for CIM

All the system in the CIM environment must be able to communicate with each other. Further work on interfacing is in chapter eleven of this book.

### **FUNCTION OF THE COMPUTER IN CIMS**

The functions of the computer in a CIM can be summarized below thus;

- (i) It has a machine control for example CNC
- (ii) Most of CIM operate under Direct Numerical Control (DNC)
- (iii) It also has a function in the production control which is based on the data entered into the computer.
- (iv) It also carry out traffic control which has the function to regulate work piece transport system which moves part between workstation.
- (v) It also regulate the secondary part handling systems at each machine tool called shuttle control.
- (vi) It also monitor the work handling system.
- (vii) The monitoring and control of cutting tool is an important feature of computer system in CIM.
- (viii) It is also possible to programme the system computer to generate various reports desired by management on system performance.

### **CIMS DATA FILES**

The CIMS data files, which are used to control the operation of the manufacturing system are;

- (i) Part program file – This is a separate program prepared for each part to perform each operations.
- (ii) Routing File – This is the file that contains the list of workstations in which each part must be processed. Alternate routings for the parts were also provided in the file.
- (iii) Pallet Reference File – It is fixtured only for a certain parts.
- (iv) Station Tool File – The code of the cutting tools are store for kept for each workstation. It is used to control the tools.
- (v) Part Production File – It contains the part production rate for the various machines.
- (vi) Tool - Life - File – This is a tool-life file for each cutting tool in the system.

### **ADVANTAGES OF CIM**

Some of the advantages to be derived for implementing a CIM approach are;

- (i) It offers a complete flow of production and management information throughout the entire organisation to all levels.
- (ii) There is communication links with interfacing between all hardware and software.
- (iii) It is possible to standardize the software packages, achieving the transferability of information from engineering applications to commercial applications and vice versa.
- (iv) It is also possible to respond quickly, both in quantity and type, to customer demands.
- (v) The output is more with a little workforce, and still able to maintain a high quality.

(vi) It also assists in the minimization of stock levels, inventory and work in progress.

### **PROBLEMS ASSOCIATED WITH CIMS**

CIM implementation involves the total integration of all areas of a manufacturing company from the top management level to the shop floor workers. Therefore, to implement all what is associated with CIM, the following problems can be created;

- Some middle level and top management may lack some of the technical details of CIM.
- There may be poor integration and flow of information between management and their subordinate in their various departments.
- Understanding the market requirement and the integration of the need to the products production before introducing to the market.
- Unwillingness to share vital information which can make the company to progress.
- Incorrect and insufficient evaluation and the appraisal of implementer CIM which can be due to lack of knowledge.
- The change of technology, which can make some of the instrument or machines to become obsolete.

### **ARTIFICIAL INTELLIGENCE AND EXPERT SYSTEMS**

Artificial Intelligence is the field of research, which stimulates human thought processes and actions. It can use or develop a computer systems in stimulating the human thought processes and actions. The goal of artificial intelligence is not to replace human intelligence, which is actually not replaceable. But it help people to be more productive than before.

In the past, people used intuition, reasoning and memory to solve the unstructured problem. The computers used calculation power to solve structural problems. In industry or in commerce, most organization have been able to computerize the tasks once done by human being like clerks, or managers or in the production line. This is the beginning of automation.

It is now to see the introduction of a new tool known as Artificial Intelligence (AI). It attempts to develop computer system that can mimic or simulate human thought processes and actions. The human thought and action includes;

- Reasoning;
- Learning from the past action;
- Human senses such as vision and touch;

It is however noted that although there are effort to do exactly what human being can do, and that various tools have been developed that have practical application in law, manufacturing, business, law, medicine and many other fields, they cannot perform exactly like human being.

Basically, there are three areas in which the human talents and abilities has been enhanced with AI. Artificial Intelligence (AI) have become very popular in Computer Aided Process Planning (CAPP). Artificial Intelligence (AI) is a computer capability that enables the computer to think and make decisions.

### **ROBOTICS**

Robotics is the field of study concerned with developing and using robots. Robots by definition are so many computer-controlled machines that mimic or imitate the motor activities of

humans. There are so many types of robot used in factories and in assembly line which are programmed to do more than one task. It can also be used to take some hazardous or dangerous, repetitive task always found in assembly line. There are three types of robots, they are;

### **Industrial Robots**

They are used in the factories to perform certain assembly line tasks. Some of the examples of industrial robots are automobile plants to do welding, painting, and loading. It can also be used in a garment industry; robot can cut pattern which create pieces of fabric for clothing.

### **Perception Systems**

This is where some robots imitate some of the human sense. Some recently developed example is the robots with television-camera vision systems. It can also be used for;

- Guiding the machine tools
- Inspection products;
- Identifying and sorting parts; and
- For welding.

Some other kinds of perception systems rely on a sense of touch, like the ones used on micro computer assembly lines which put parts into place.

### **Mobile robots**

It is possible for some robots to act as transporters. They carry mail through an office, following a programmed route. Other mobile robots acts as computerized carts to deliver supplies and equipment at medical centres.

## **KNOWLEDGE – BASED (EXPERT) SYSTEMS**

Knowledge-based system is a category of artificial intelligence programmes that makes use of information gathered from previous projects. Professionals who are well skilled and expert in particular field of specialization like, Production, Medicine, Law, Accounting, other Engineering fields, are generally very scarce and are well paid for acquiring such knowledge.

If one has the ability to capture the knowledge of human expert and made it accessible to everyone through a computer programme, definitely the price will be very high. The expert has the ability to create their own computer programme using their knowledge and what they know. This is what is known as expert systems or knowledge-based.

Expert system can therefore be defined as computer programs that provide advice to decision makers who would otherwise rely on human experts. The programme differs from the normal programmes in the sense that;

- Conventional programmes are used to perform routine tasks on data. While the;
- Expert system programmes are used to provide advice on very specialized tasks that typically require a human expert.

Instead of using a database, expert system use knowledge bases. It involves the use of specific facts, rules to relate these facts, and user input to formulate recommendations and decisions. Many expert systems use so called fuzzy logic which allows users to respond to questions in a human like way or used to allow users human like input.

The following areas have enjoyed expert system like medicine, chemistry, photography, geology, military science. Expert systems are created using a programming language or a shell.

Shell is special kinds of software that allows a person to custom-build a particular kind of expert system.

### **VIRTUAL REALITY**

Supposing, it is possible for you to create and virtually experience any new form of reality you wish, you can explore the impossibility is rapidly becoming possible with the use of artificial intelligent tool known as virtual reality. Virtual reality can also be called artificial reality or virtual environments. The hardware used in virtual reality includes;

- Head gear and gloves;
- Ear phones; and
- Three-dimensional stereoscopic screens.

It can be used to simulate important experiences or tracing environments such as:

- Flying
- Surgical operations;
- Spaceship repair; or
- Nuclear disasters clean up.

### **REFERENCES**

1. **Adejuyigbe S.B. (1994):** Computer Appreciation for Production Planning and Control in some Nigeria Companies Proceedings of first National Conference of the Nigerian Institution of Production Engineers Faculty of Engineering University of Benin, Benin-City: 121-141.
2. **Adejuyigbe, S.B. (1977):** Computer-Aided Design and Drafting (CADD) in Process Modelling of Sand Casting M. Eng. Thesis Submitted to Mechanical Engineering Department, Federal University of Technology, Akure.
3. **Adejuyigbe, S. B. (2002) –** A Computer – Aided Design (CAD) of Sand Casting Operations. PhD Thesis in the Department of Mechanical engineering, Federal University of Technology, Akure.
4. **Adejuyigbe, S.B (2002):** CAD/CAM for Manufacturing. An Engineering Textbook for University and Polytechnics TOPFUN Publications, Akure, Nigeria.
5. **Adejuyigbe, S.B. and Aderoba A.A. (2000):** An Appraisal Foundry Technology in Nigeria. Nigeria Journal of Engineering Management, Ondo, Vol. 1 (2): 1-12
6. **Adejuyigbe, S.B. and Akinola S.K. (2002):** Industrial Automation and Communication in Nigeria Industries (Case Study of Industries in Osun State).
7. **Adejuyigbe S.B. and Ogunlade, O. (1997)** Computer-Aided Design and Drafting (CADD) for Industrial Design and Development Journal of Industrial Design and Technology (JINDEST), Federal University of Technology, Akure, Vol 1 (1): 83-89
8. **Asfalh, C.R. (1985) –** Robots and Manufacturing Automation. Second Edition. John Willey and Sons Inc, New York.
9. **Bedworth, D.D. and Bailey, J.E (1982) –** Integrated Production Systems. Management, analysis, Design – John Wiley and Sons, New York.
10. **Brown, W.C. (1990) –** Drafting for Industry. The Good Heart – Williox company Inc. Publishers, Illionis.

11. **Crown K. (1992):** Computer Process Planning DRPM Associates 2613 Vou. Olivera, Palos Veides, C. A. 90274. Internet File 1/A: 1 Computer – Aided Process Planning Hm: 1-4
12. **Gbotosho** Institute of Architecture Biennial General Meeting Conference, Zaria on Nov. 20-22:3-28
13. **Groover. M.P. and Cimmers, E.M. (1984)** CAD/CAM: Computer-Aided Design/Manufacturing Prentice-Hall International Inc. London.
14. **Haslehurst, M. (1980)** Manufacturing Technology. The English Language Book society and Hodder and Stoughton, Britain
15. **Hirschtick I. (1996):** A Solid Foundation for CAD, Mechanical Engineering Journal USA, Vol. 118(8): 71
16. **Hugh, J. (Internet, 2000)** – A Boolean Algebra Approach to High-Level Process Planning. Thesis Accepted in Partial fulfilment of the Requirements for the Degree of Doctor of Philosophy (Ph.D)
17. **Inuwa, I.K. (1995):** Foundries Subsystem. A Crucial Linkage for the successful Operations of the other Industries Basic Technology, Experience. The Nigerian Engineers Official Journal of the Nigerian Society of Engineers. Dec. 1995.
18. **Kantoyama K. (1991):** Development of Automatic Drawing Capturing System NSX press 5000, Nippon Steel Technical Report, Tokyo No 51 : 37-42
19. **Lascoe, D.D., Nelson, C.A. and Porter, W.H. (1977)** Machine Shop Operations and Set Ups. American Technical Society, Chicago.
20. **Lindberg, R.A. (1990)** – Process and Materials of Manufacture Prentice Hall, Eaglewood Cliffs, New Jersey.
21. **Ogedengbe, T. I. Adejuyigbe S. B. and Aderoba, A.A. (2002)** Adoption of Computer Integrated Manufacturing in Nigeria. Nigerian Journal of Engineering Management Accepted for Publication
22. **Ogunlade, O. (1995)** CAD/CAM for Manufacture. M.Eng. Handbill for 1994/95 Session at the Federal University of Technology, Akure, Nigeria
23. **O’Leary, T.J. and O’leary L.I (1997)** – Computer Essential, Multimedia Edition, 1997-1998. Mc. Graw-Hill Companies.
24. **Riley, P., Cumbers, D., Hodges, B., Hunt, P.C., and Townsend, B.J. (1994)** – Computer Aided Engineering. City and Guilds/Macmillan, England.
25. **UNIDO, (1982):** Metal Production Development Units – Castings Development and Transfer of Technology Series 16:33-69.
26. **Wright, R.T. (1990)** Manufacturing System. The Good heart Willcox Company, Inc,
27. **Voisinet D. D. (1987):** Introduction to Computer – Aided Drafting Second Edition. Mc Graw Hill International Editions.