

PHS 383 REMOTE SENSING

COURSE OUTLINE

1.0: Concept of remote sensing

- 1.1. Definition of remote sensing
- 1.2. Electromagnetic radiation
- 1.3. Electromagnetic spectrum
- 1.4. Interaction with atmosphere
- 1.5. Passive and active sensing
- 1.6. Characteristics of Images

2.0: Sensors

- 2.1: Sensor on the ground, in the air and in the space
- 2.2: Satellite characteristics
- 2.3: Spectral resolution
- 2.4: Thermal imaging
- 2.5: Weather satellites
- 2.6: Land, marine observation satellites
- 2.7: Data reception

3.0: Microwaves

- 3.1: Reader basic
- 3.2: Viewing geometry and spatial resolution
- 3.3: Polarimetry

4.0: Applications

- 4.1: Agriculture
- 4.2: Forestry
- 4.3: Geology
- 4.4: Hydrology
- 4.5: Oceans and coastal

CONCEPT OF REMOTE SENSING

What exactly is remote sensing?

Remote sense is the science (and to some extent, art) of acquiring information about the Earth's surface without actually being in contact with the Earth. This is done through sensing and recording reflected or emitted energy, processing, analyzing and applying the information therein.

The process involves an interaction between incident radiation and the targets of interest. For instance, the use of imaging systems, where the following seven (7) elements are involved:

1. **Energy source and illumination A:** The first requirement of remote sensing is to have an energy source, which illuminate or provides electromagnetic energy to the target of interest.
2. **Radiation and the atmosphere B:** This is the energy that travels from the source to the target, which comes into contact with and interacts with the atmosphere as it passes. This may take place in a second time as the energy travels from the target to the sensor.
3. **Interaction with the target C:** Once the energy makes its way to the target through the atmosphere, it interacts with the target depending on the properties of both the target and the radiation.
4. **Recording of energy by the sensor D:** After the energy has been scattered by emitted from the target, we require a sensor (remote – not in contact with the target) to collect and record the electromagnetic radiation.
5. **Transmission, Reception and processing E:** The energy recorded by the sensor has to be transmitted, often in electromagnetic form, to a receiving and processing station where the data are processed into an image (hardcopy and or digital).
6. **Interpretation and analysis F:** The processed image is interpreted visually and/or digitally or electromagnetically to extract information about the target which was illuminated.
7. **Applications G:** This is the final element of the remote sensing process, is achieved when we apply the information we have been able to extract from the imagery about the target in order to better understand it, reveal some new information, or assist in solving a particular problem.

The above listed elements comprise the remote sensing process from beginning to end.

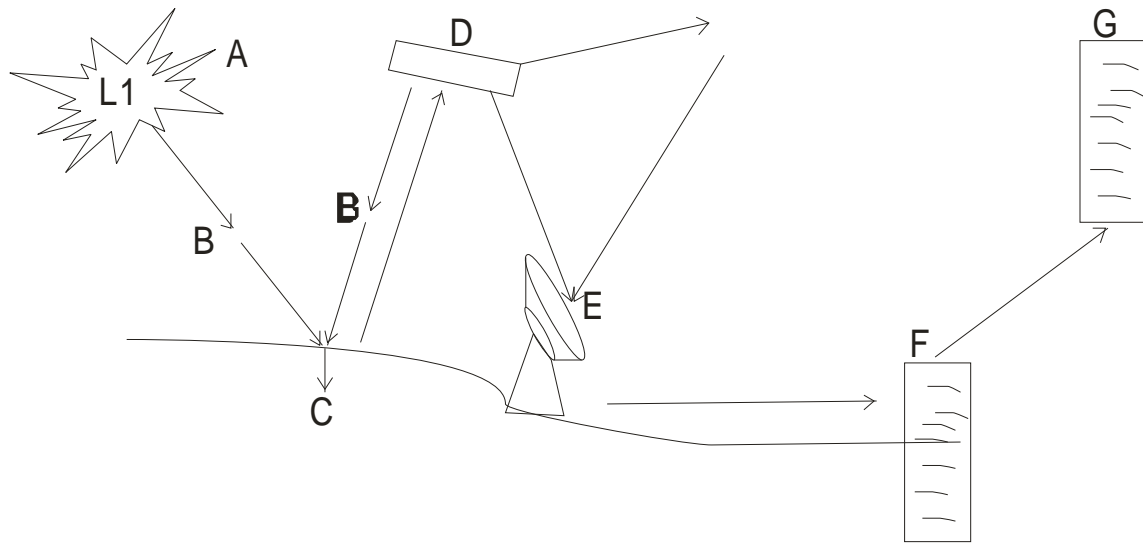

Electromagnetic Radiation

All electromagnetic radiation has fundamental properties and behaves in predictable ways according to the basics of wave theory. Electromagnetic radiation consists of an electrical field (E), which varies in magnitude and direction in the direction in which the radiation is traveling and a magnetic field M oriented at right angle to the electrical field; both fields travel at the speed of light (C)

Two characteristics of electromagnetic radiation are particularly important to understanding remote sensing. These are wavelength and frequency, related by $C = f\lambda$

λ = wavelength

F = Frequency (Cycles per second measured in Hz)

C = Speed of light (3×10^8 m/s)

These two properties are inversely related to each other. The shorter the wavelength, the higher the frequency and vice-versa. Hence, understanding the characteristics of electromagnetic radiation in terms of their f and λ is crucial to understanding the information to be extracted from remote sensing data.

ELECTROMAGNETIC SPECTRUM

The electromagnetic spectrum ranges from the shorter wavelength (including γ and x-rays) to the longer wavelengths (including microwaves and broadcast radio waves). There are several regions of the electromagnetic spectrum which are useful for remote sensing.

For most process, the Ultra-violet (UV) has the shorter wavelengths which are practical for remote sensing. Some earth surface materials, primarily rocks and minerals, emit visible light when illuminated by UV radiation.

The light which our eyes “our remote sensors” can detect form part of the visible spectrum. It is important to recognize how small the visible portion is relative to the rest of the spectrum, because there is a lot of radiation around us which is “invisible” to our eyes, but can be detected by other remote sensing instruments and used to our advantage. This visible wavelength covers a range from approximately 0.4 to 0.7µm, while the longest visible wavelength is red, the shortest is violet. Common wavelengths of what we perceive as particular colours from the visible portion of the spectrum are:

Violet:	0.4 – 0.446 µm	} It is important to note that this is the only portion of the spectrum we can associate with the concept of <u>Colours</u>.
Bleu:	0.446 - 0.500 µm	
Green:	0.500 – 0.578 µm	
Yellow:	0.578 – 0.592 µm	
Orange:	0.592 – 0.620 µm	
Red:	0.620 – 0.7 µm	

Blue, Green and Red are called the **Primary Colours** (wavelength of the visible spectrum), because no single primary colours can be created from the other two, but all other colours can be formed by combining Blue, Green and Red in various proportions. Sunlight is seen as uniform homogeneous colours, as it actually composed of various wavelengths of radiation, primarily ultraviolet, visible and infrared portions of the spectrum.

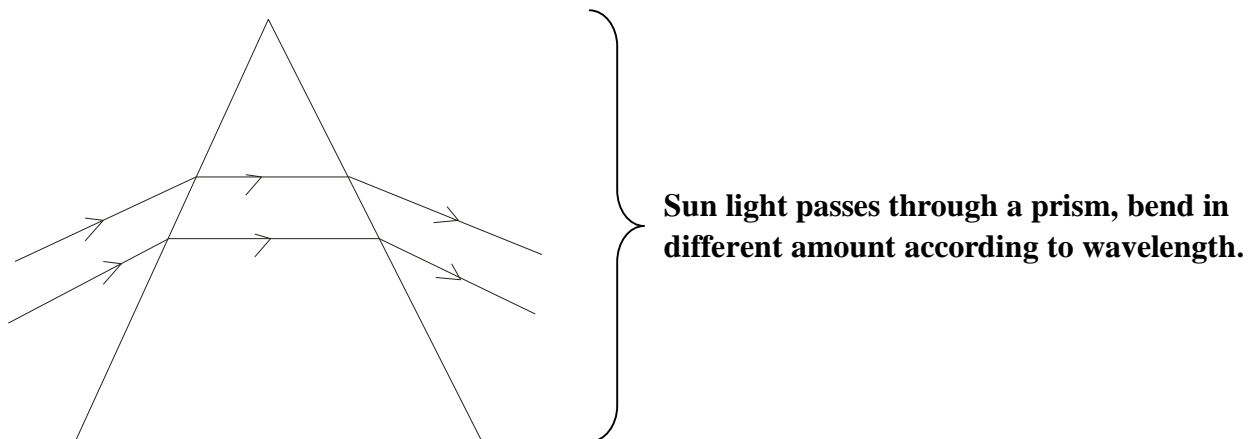

After Red portion of the spectrum, next is Infrared (IF) region, which covers between 0.7µm and 100µm. It can be divided into two categories on the basis of their radiation properties. These are

the reflected (IR) and the emitted or thermal(IR).Radiation in the selected IR regionis used for remote sensing purposes in ways similar to radiation in the visible portion. It is the energy that the radiation emits from the Earth's surface in the form of heat.

Another portion of the spectrum that is of more recent interest to remote sensing is the microwave region (from about 1mm to 1m), which covers the longest wavelength used for remote sensing, close to the wavelength used for radio broadcasts.

INTERACTION WITH ATMOSPHERE

Before radiation used for remote sensing reaches the Earth's surface, it has to travel through some distance of the Earth's atmosphere. Particles and gases with the atmosphere can affect the incoming light and radiation. These effects are caused by scattering and absorption.

Scattering:Occurs when particles or large gas molecules present in the atmosphere interact with and causes the EM radiation to be redirected from its original path.The scattering that takes place depends on several factors including the wavelength of the radiation, abundance of particles or gases and distance the radiation travels through the atmosphere. There are three types of scattering which take place.

Rayleigh Scattering: This occurs when particles are very small compared to the wavelength of the radiation; particles could be as small as specks of dust or Nitrogen and Oxygen molecules.Rayleigh scattering causes shorter wavelengths of energy to be scattered much more than longer wavelength. It is the dominant scattering mechanism in the upper atmosphere (responsible for the bluish coloursin the sky during the day).

Mie Scattering:Occurs when the particles are just the same size as the wavelength of the radiation. Dust, pollen, smoke and water vapour are common causes of Mie scattering; which tends to affect longer wavelengths than those affected by Rayleigh scattering. It occurs mostly in the lower portions of the atmosphere where larger particles are more abundant and dominates when cloud conditions are overcast.

Non-Selective Scattering: This occurs when particles are much larger than the wavelength of the radiation. Water droplets and large dusts particles can cause this type of scattering, it takes its name from the fact that all wavelengths are scattered about equally. It causes fog and clouds to appear white to our eyes because blue, green and red lights are all scattered in approximately in equal quantities (**Blue + Green+ Red lights = White light**).

Absorption:In contrast to scattering, this phenomenon causes molecules in the ozone atmosphere to absorb energy at various wavelengths. Ozone, carbon dioxide and water vapour are the three main atmospheric constituents which absorb radiation.

Ozone: Serves to absorb the harmful (to most living things) ultraviolet radiation from the sun. Without this protective layer in the atmosphere, our skin would burn when exposed to sunlight.

Carbon Dioxide: Referred to as a *greenhouse gas*, because it tends to absorb radiation strongly in the infrared portion of the spectrum that are associated with thermal heating; which serves to trap this heat inside the atmosphere.

Water Vapour: Water vapour in the atmosphere absorbs much of the incoming long-wave infrared and short-wave microwave radiation (between 22 μ m and 1m). The presence of water vapour in the lower atmosphere varies greatly from locations to locations and at different times of the year. For instance, the air mass above a desert has little water vapour to absorb energy while the tropics have high concentration of water vapour (i.e., high humidity).

PASSIVE AND ACTIVE SENSING

Passive Sensor: Remote sensing systems which measure energy that is naturally available are called passive sensor. It can only be used to detect energy when the naturally occurring energy place during the time when the sun is illuminating the Earth; since there is no reflected energy available from the sun at night.

Active Sensors: This provides their own energy source for illumination. The sensor emits radiation which is directed to the target to be investigated. Advantages of the active sensors include the ability to obtain measurements anytime, regardless of the time of day or season. It can be used for examining wavelengths that are not sufficiently provided by the sun, such as micro waves. However, active systems required the generation of a fairly large amount of energy to adequately illuminate target. Examples of active sensors are a laser flouresensor and a Synthetic Aperture Radar (SAR).

CHARACTERISTICS OF IMAGES:

EM energy may be detected either photographically or electronically. Photographic process uses chemical reactions on the surface of light sensing film to detect and record energy variation. Hence, it is important to distinguish between the term image and photographs in remote sensing. An *image* refers to any pictorial representation, regardless of what wavelengths or remote sensing device has been used to detect and record the EM energy.

A *photograph* refers specifically to image that have been detected as well as recorded on photographic film. Photos are normally recorded over the wavelength range from 0.3 μ m to 0.9 μ m – the visible and reflected infrared; hence, all photographs are images, but not all images are photographs. A photograph can also be represented and displayed in digital format by

subdividing the image into small equal sized and shaped areas, called *Picture Elements or Pixels*, representing the brightness of each area with a numeric value and displaying remote sensing data, either pictorially or digitally, are interchangeable as they convey the same information.

Sensors

Here, we shall look at component of the remote sensing process by examining the characteristics of remote sensing platforms and sensors, and the data they collect; how these data are collected and recorded by the sensor. In order for a sensor to collect and record energy reflected or emitted from a target or surface, it must reside on a stable platform removed from the target or surface being observed. The platform for remote sensor may be located on the ground, on an aircraft or balloon (or some other platform within the Earth's atmosphere) or on the space craft or satellite outside of the Earth's atmosphere.

Ground-Based Sensors

These are often used to record detailed information about the surface, which is compared with information collected from the aircraft or satellite sensors. It is sometimes used to better characterize the target which is being imaged by these other sensors, making it possible to better understand the information in the imagery. It may be placed on a ladder, scaffolding, tall building, crane etc.

Aerial Platform: These are primarily stable winged aircraft; helicopters are occasionally used. Aircrafts are often used to collect very detailed images and facilitates the collection of data over any portion of the Earth's surface at anytime.

In Space: Remote sensing is sometimes conducted from the space shuttle more commonly, from satellites. Satellites are objects which revolve around another object, in this case, the Earth. For instance, the moon is a natural satellite, while Man-made satellites include platform launched for remote sensing, communication, and telemetry, for navigation purpose. Because of the orbits, satellite permits repetitive coverage of the Earth's surface on a continuing basis.

Satellites Characteristics

Although ground based and aircraft platforms may be used to view and image target, satellites provide a great deal of the remote sensing imagery commonly used today. Satellites have several unique characteristics which makes them particularly useful for remote sensing of the Earth's surface. The path followed by a satellite is referred to as its *orbit*. Satellite orbit are matched to the capability and objective of the sensor(s) they carry. Orbit selection can vary in terms of altitude (height above the Earth's surface) and their orientation as well as the rotation relative to the Earth. Satellites at very high altitudes, which view the same portion of the Earth's surface at all times have geostationary orbits. These geostationary satellites, at altitudes of approximately 36,000 kilometers, revolve at speed, which match the rotation of the Earth relative the Earth's surface. This allows the satellite to observe and collect information continuously over specific areas.

Weather and communication satellites commonly have these types of orbits. Because of high altitude, some geostationary satellites can monitor weather and cloud patterns covering an entire hemisphere of the Earth. Many remote sensing platforms are designed to follow an orbit (basically North-South) which, in conjunction with the Earth's rotation (West-East), allows the orbit to cover most of the Earth's surface over a certain period of time. These are near-polar orbit.

Many of the satellite orbits are also *Sun-synchronous*, such that they cover each area of the world at a constant local time of the day called *Local Sun Time*.

Most of the remote sensing satellite platforms today are in *Near-Polar Orbits*, which means that, the satellites travels northward on one side of the Earth and towards the southern pole on the second half of its orbit; these are called *ascending and descending passes*, repeatedly. When the orbit is sun synchronous, the ascending pass is most likely on the shadowed side of the Earth while the descending pass is on the sunlight side.

As a satellite revolves round the earth, the sensor "sees" a certain portion of the Earth's surface. The area imaged on the surface is termed swath. Imaging swaths for space borne sensors generally vary between tens and hundreds of kilometers wide. This apparent movement allows the satellite swath to cover a new area with each consecutive pass. The satellite's orbit and the rotation of the earth work together to allow complete coverage of the Earth's surface after it has complete one complete cycle of orbits.

The interval of time required for the satellite to complete its orbit cycle is not the same as the *Revisit Period*. This revisit period is an important consideration for a number of monitoring applications, especially when frequent imaging is required. For instance, monitoring speed of an oil spill or extent of flooding.

Spatial Resolution

For some remote sensing instruments, the distance between the target being imaged and the platform plays a large role in determining the detail of information obtained and the total area imaged by the sensor. Sensors onboard platforms far away from their targets typically view a larger area but cannot provide great details. For instance, compare what an astronaut onboard a space shuttle sees of the Earth to what you can see from the air plane. Astronauts can see the entire country at glance but cannot distinguish between individual houses, while flying over a city or town, one can see individual buildings and cars, but will view much smaller area than the astronaut. There is similar difference between satellite images and air photos.

Spatial resolution of passive sensor depends primarily on their instantaneous field of view (IFOV). The IFOV is the angular cone of visibility of the sensor and determines the area on the Earth's surface which is seen from a given altitude at one particular moment in time. This area in the ground is called the *Resolution Cell* and determines a sensor's maximum spatial resolution.

Spectral Resolution: This describes the ability of a sensor to define fine wavelengths intervals. The finer the spectral resolution, the narrower the wavelength ranges for a particular channel or band.

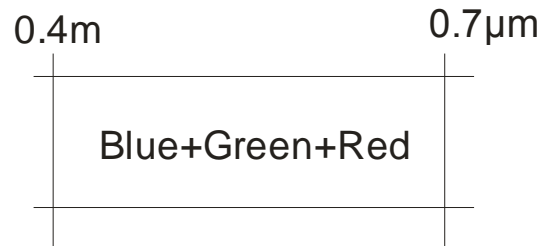

Black and White Films

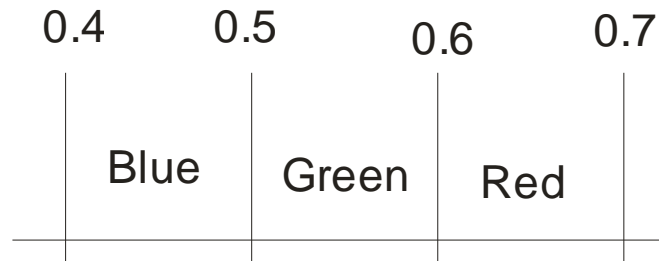

Colours Films

Black and white films record wavelengths extending over much, or all of the visible portions of the EM spectrum. Its spectral resolution is fairly coarse, as the various wavelength of the variable spectrum are not individually distinguished and the overall reflectance in the entire portion is recorded.

Colours film is also sensitive to the reflected energy over the visible portion of the spectrum but has higher spectral resolution, as it is individually sensitive to the reflected energy at the blue, green, red wavelengths of the spectrum.

Many remote sensing systems record energy over several separate wavelength ranges at various spectral resolutions. These are known as *Multi-spectral senses*. We also have advanced multi-spectral sensors called *Hyper-spectral Sensors*, which detects hundreds of very narrow spectral bands throughout the visible near-infrared and mid-infrared portions of the EM spectrum.

Radiometric Resolution: While the arrangement of pixels is denser than the spatial structure of an image, the radiometry characteristics explain the actual information content in an image. Every time the image is acquired on film or by a sensor, its sensitivity to the magnitude of the EM energy determines the radiometric resolution. The radiometric resolution of an imaging system describes its ability to discriminate very slight differences in energy. The finer the radiometry resolutions of sensor the more sensitive it is to detecting small differences in reflected or emitted energy.

Temporal Resolution: In addition to spatial, spectra and radiometric resolutions, the concept of temporary resolution is also important in a remote sensing system. Recall the concept of revisit period, which refers to the length of time it takes for a satellite to complete one entire orbit cycle. Revisit period of a sensor is usually several days. Therefore the absolute temporal resolution of a remote sensing system to image the exact same area of the same viewing angle a second time is equal to this period. Hence, the actual temporal resolution of a sensor depends on a variety of factors: satellite/sensor capabilities, the swath overlap and latitude.

Cameras and Aerial Photography: Cameras and their use for aerial photography are the simplest and oldest of sensors used for remote sensing on the earth's surface. Cameras are passive optical sensors that use a lens or system of lenses, collectively referred to as the optics, to form an image on the focal plane at which the image is sharply defined.

Photographic film are sensitive to light from 0.3 μm to 0.9 μm in wavelength covering the ultraviolet (UV), visible and near-infrared.

Panchromatic Films: Sensitive to the UV and the visible portion of the spectrum, produced black and white images and commonly used for aerial photography.

Cameras can be used in variety of platforms, which includes ground-based stages, helicopters, aircraft and spacecraft. Most of the aerial photographs are classified as oblique or vertical depending on the orientation of the camera relative to the ground acquisition. Oblique aerial photographs are taken with cameras pointed to the side of the aircraft. It can be useful for covering very large areas in a single image and for depicting terrain relief and scale.

Vertical photographs taken with a single-lens frame camera is the most useful of aerial photography for remote sensing and mapping purposes. These cameras are specifically designed for capturing a rapid sequence of photographs while limiting geometric distortion. They often linked with navigational systems onboard the aircraft platform to allow for accurate geographic coordinates to be instantly assigned to each photograph.

Thermal imaging

Thermal sensors use photo detectors sensitive to the direct contact of photons on their surface, to detect emitted thermal radiation. The detectors are cooled to temperatures close to absolute zero

in order to limit their own thermal emissions. Thermal sensors measure the surface temperature and thermal properties of the targets.

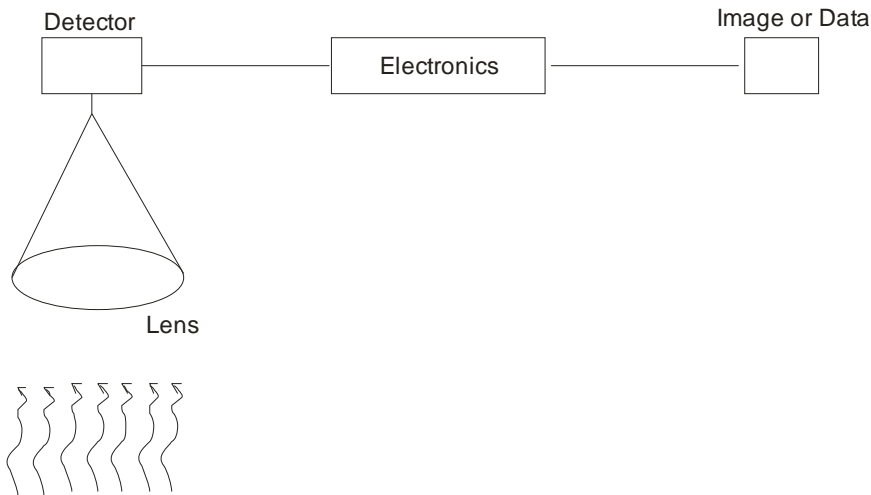

Thermal images are typically scanners that detect emitted radiations in only the thermal portion of the spectrum. Because of the relatively long wavelength of the thermal radiation compared to visible radiation, atmospheric scattering is minimal while absorption by atmospheric gases normally restricts thermal sensing to two specific regions between 3 to 5 μm and 8 to 14 μm . Thermal imagery can be acquired during the day or night (because the radiation is emitted and not reflected) and is used for variety of applications such as military reconnaissance, disaster management and heat loss monitoring.

Weather Satellite/Sensors

Weather monitoring and forecasting was one of the first civilian application of satellite remote sensing. This satellite uses sensors which have fairly coarse spatial resolution and provide large area coverage. Their temporal resolution are generally quite high, providing frequent observations of the Earth's surface, atmospheric moisture and cloud cover, which allows for near continuous monitoring of global weather condition and hence forecasting. There are various representatives satellite/sensors used for meteorological application:

i. Geostationary Operational Environmental Satellites (GOES)

This is the follow-up to the application technology satellite (ATS) series designed by NASA (National Aeronautics and Space Administration) for National Oceanic and Atmospheric Administration (NOAA) to provide nation weather service with frequent, small-scale imaging of the Earth's surface and cloud cover. The GOES series of satellites have been used extensively by meteorologists for weather monitoring and forecasting for over 20years.

Two generation of GOES satellites have been launched, each to measure emitted and reflected radiation from which atmospheric temperature winds, moisture and cloud cover can be derived. The first is GOES1 launched 1975 through GOES7 launched 1992. Due to their design, these satellites were capable of viewing the Earth only on a small percentage of time (approximately

5%). These sensors allow meteorologists to monitor specific weather trouble spots to assist in improved short-term forecasting.

GOES BANDS AND THEIR APPLICATIONS

BANDS	WAVELENGTH RANGES (µm)	SPATIAL RESOLUTIONS	APPLICATIONS
1	0.52 0.72 (Visible)	1km	Cloud, pollution and haze detection severe storm identification
2	3.78 – 4.03 (Short wave IR)	4km	Identification of fog at night, discriminating water clouds and snow or ice clouds during daytime; detecting fire and volcanoes, night time determination of sea surface temperature.
3	6.47 – 7.02 (Upper level water vapour)	4km	Estimating regions of mid-level moisture content and advection, tracking atmospheric motion.
4	10.2 – 11.2 long wave IR	4km	Identification of cloud-drift winds severe storms, heavy rainfall
5	11.5 – 12.5 IR window sensitive to water vapour	4km	Identifying low-level moisture, determination of sea surface temperature, air bourn dust volcanic ash.

NOAA is responsible for another series of satellite which are useful for meteorological applications. Two satellites, each pending global coverage work together ensure that data for any region of the earth is not more than six hours old. One satellite crosses the Equator in the early morning from north to south while the other crosses in the afternoon. The primary sensor onboard the NOAA satellite, used for meteorology and small-scale earth observation and reconnaissance are the Advanced Very High Resolution Radiometer (AVHRR). It detects radiation in the visible, near and mid infrared, and thermal infrared portions of the EM spectrum.

AVHRR BANDS AND THEIR APPLICATIONS

BANDS	WAVELENGTH RANGES (µm)	SPATIAL RESOLUTIONS	APPLICATIONS
1	0.58 – 0.68 (Red)	1.1km	Cloud, snow and ice monitoring
2	0.725 – 1.1 (Near IR)	1.1km	Water, vegetation and agriculture surveys
3	3.55 – 3.93 (Mid IR)	1.1km	Sea surface temperature, volcanoes and forest fire activity
4	10.3 – 11.3 (Thermal IR)	1.1km	Sea surface temperature, soil moisture
5	11.5 – 12.5 (Thermal IR)	1.1km	Sea surface temperature, soil moisture

Land Observation Satellite/Sensors

Many of the weather satellite systems used for monitoring the Earth's surface is not optimized for detailed mapping of the land surface. The first satellite designed specifically to monitor the Earth's surface launched in 1972 by NASA (National Aeronautics and Space Administration), referred to as **LandSat-1**; to test the feasibility of collecting multi-spectral earth observation data from an unmanned satellite platform. The success of Landsat is due to several factors: a combination of sensors with spectral bands tailored to Earth observation; functional spatial resolution; and good areal coverage (swath width and revisit period).

All Landsat satellites are placed in near polar, sun-synchronous orbit. The first three satellites (Landsat's 1 - 3) are at altitude around 900km and have them revisit period of 18days, while the later satellites are around 700km and have a revisit period of 16days. All Landsat satellites have equator crossing times in the morning to optimize illumination conditions. A number of sensors have on board the Landsat series of satellites including the Return Beam Vidicom (RBV) camera systems, the Multi Spectral Scanner (MSS) systems, and the Thematic Mapper (TM).

Marine Observation Satellites/Sensor

The Earth's ocean covers more than two-third (2/3) of the Earth's surface and plays an important role in the global climate system. They also contain an abundance of living organisms and natural resources which are susceptible to pollution and other man-made hazards. The meteorological and land observations satellites/sensors can be used for monitoring the oceans of the planet; there are other satellites/sensor systems designed specifically for this purpose. The coastal zone colours scanner (CZCS) for monitoring the earth's oceans and water bodies. The primary objective of this sensor is to observe ocean colours and temperature, especially in coastal zones with sufficient spatial and spectral resolution to detect pollutants in the upper level of the ocean and to determine the nature of materials suspended in the water column. The ocean-observing satellite systems are important for global and regional scale monitoring of ocean pollution and health, and assists scientists in understanding the influence and impact of the oceans on the global climate system.

Other Sensors

Video: Video cameras provide a useful means of acquiring timely and inexpensive data and vocally annotated imagery. Cameras used for video recording measures radiation in the visible, near infrared and sometimes mid-infrared portion of the EM spectrum.

Laser Fluorescence: This illuminates the target with specific wavelength of fluorescence radiation. This technology has been proven for ocean applications like chlorophyll mapping and pollutant detection etc.

Lidar: Light detection and ranging, an active imagine technology similar to RADAR. It is useful for measuring surface and water depth relative to the water surface. It is also used in atmosphere

studies to examine the particle content of various layers of the Earth's atmosphere and acquire air density readings and monitor air currents.

RADAR:Radio Detection and Ranging (RADAR) systems are active sensor, which provide their own source of EM energy. Active radar sensor, whether airborne or space borne, emits microwave radiation in a series of pulses from an antenna. Because RADAR provides its own energy source, images can be acquired day or night. It is able to penetrate through clouds and most rain, making it an all weathers sensor.

Data Reception:Data obtained during airborne remote sensing missions can be retrieved once the aircraft lands; then processed and delivered to the end user. While data acquired from satellites platforms need to be electronically transmitted to earth, since the satellite continues to stay in the orbit during its operational lifetime. The technology designed to accomplish this can also be used by an aerial platform if the data are urgently needed on the surface.

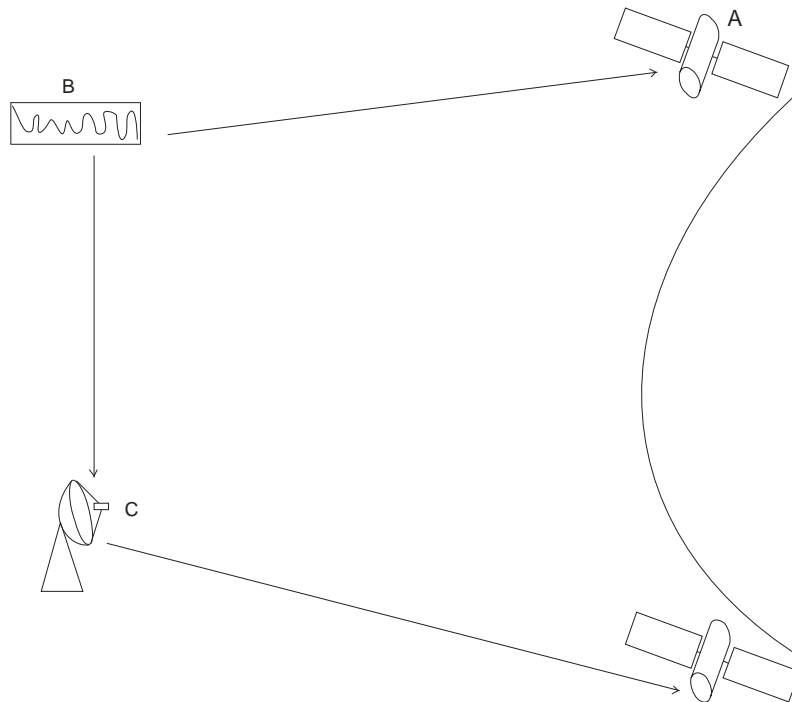

There are three main options for transmitting data acquired by satellite to the surface. The data can be directly transmitted to Earth if a Ground Receiving Station (GRS) is in line of sight of the satellites A. If otherwise, the data can be recorded on board the satellite (B) for transmission to a GRS at a later time. Data can be relayed to the GRS through the Tracking and Data Relay Satellite System (TDRSS, (C), which consists of a series of communications satellites in geosynchronous orbit. The data are transmitted from one satellite to another until they reach the appropriate GRS. The received data at the GRS are in raw digital format, which is then processed into corrected systematic, geometric and atmospheric distortions to the imagery and be translated into a standardized format. The data are written into a storage medium like tape, disk or CD.

Note: http://www.ccrs.nrcan.gc.ca/ccrs/learn/terms/glossary/glossary_e.html

http://www.ccrs.nrcan.gc.ca/ccrs/date/stations/pass_e.html

http://www.ccrs.nrcan.gc.ca/ccrs/date/stations/gss_e.html

http://www.ccrs.nrcan.gc.ca/ccrs/date/stations/cc_e.html

http://www.ccrs.nrcan.gc.ca/ccrs/date/stations/grss_e.html

MICROWAVE REMOTE SENSING

This encompasses both active and passive forms of remote sensing. It covers on spectrum a range of 1 on to 1m in wavelength. Because of their long wavelengths compared to the visible and infrared, microwaves have special properties that are important for remote sensing. Longer wavelength microwave radiation can penetrate through cloud cover, haze dust and all but the heaviest rainfall. This property allows detection of microwave energy under almost all weather and environmental conditions so that data can be collected at any time.

Passive microwave remote sensing similar to thermal remote sensing, emits microwave energy of some magnitude, but very small amount. It detects the naturally emitted microwave energy within its field of view. They are typically radiometers or scanners and operate in much the same manner except that an antenna is used to detect and record the microwave energy. Microwave energy recorded by a passive sensor can be emitted by (i) the atmosphere, (2) reflected from the surface, (3) emitted from the surface or (4) transmitted from the substance.

The field of view must be large to detect enough energy to record a signal, hence, passive microwave sensor are characterized by low spatial resolution. Applications of microwave remote sensing include meteorology, hydrology and oceanography. By observing the atmosphere, depending on the wavelength, meteorologists and infrared portion of the spectrum by wavelength, microwave portions are often referenced according to both wavelength and frequency. Because the microwave region of the spectrum is quite large, relative to the visible and infrared, sensed wavelength range or bands with given code letter are used:Ka, K and KU bands: very short wavelengths used in early airborne radar system but uncommon today.

X-Band: Used extensively on airborne system for military reconnaissance and terrain mapping.

C-Band: Common to air-born research systems

S-Band: Used on board the Russian ALMAZ satellites

L-Band: Used on board the American SEASAT, Japanese JERS-1 satellites and NASA airborne system

P-Band: Longest radar wavelengths, used on NASA EXPT airborne research system.

Viewing Geometry and Spatial Resolution

The imaging geometry of a radar system is different from the framing and scanning systems commonly used in optical remote sensing. The side-looking viewing geometry is typical of imaging radar system (airborne). As it is with all sensing system the viewing geometry of a radar results in certain geometry distortions on the resultant imagery. There are key differences for radar imagery which are due to make side-looking viewing geometry and the fact that the radar is fundamentally a distance measuring device.

Radar Polarimetry:

In discussing microwave propagation and scattering, polarization of the radiation is an important property. For a plane EM – wave, polarization refers to the electric field vector in the plane perpendicular to the direction of propagation. While the length of the vector represents the amplitude of the wave, polarization refers to the orientation and shape of the pattern traced by the tip of the vector.

The wave form of the electric field strength (Voltage) of the EM wave can be predictable (the wave is polarized) or random (wave is un-polarized) or a combination of both. Examples of the fully polarized wave could be monochromatic sine wave with a single, constant frequency and stable amplitude.

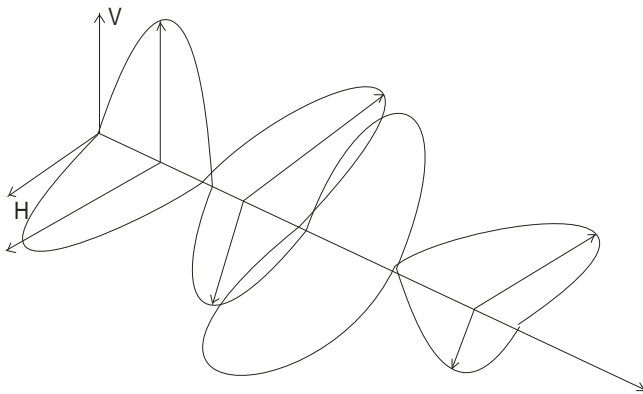

Many types of Radar are designed to transmit microwave radiation that is either polarized horizontally (v). A transmitted wave of either polarization can generate a backscattered wave with a variety of polarizations.

It is the analyses of these transmit and receive polarization combinations that constitute the science of radar polarimetry. There can be four combinations of transmit and receive polarizations:

H H: Refer to as Horizontal Transmit and Horizontal Receive

V V: Refers to as vertical Transmit and Vertical Receive

H V: Horizontal Transmit and Vertical Receive

V H: Vertical Transmit and Horizontal Receive

The first two polarization combinations are referred to as “*like polarized*” because transmit and receive are referred to as cross-polarized since transmit and receive polarization are orthogonal to one another.

Radar system can have one; two or all of these transmit/receive polarization combinations. Examples include the following types of radar systems:

- i. **Single Polarized:** HH or V V (or possibly HV or VH)
- ii. **Dual Polarized:** HH or HV, V V and VH or HH and VV
- iii. **Alternating Polarization:** HH and HH or HV, alternating with VV and VH
- iv. **Polarimetric:** HH, VV, HV and VH

Note: “Quadrature polarization” and “fully polarimetric” can be used as synonyms for polarimetric.

Polarimetric Applications: These applications include the following:

Agriculture:	For crop type identification, crop condition monitoring, soil moisture measurement and soil tillage and crop residue identification.
Forestry:	For clear cut and linear features mapping, biomass estimation, species identification and fire scar mapping
Geology:	Geological mapping
Hydrology:	For measuring wetlands and snow cover
Oceanography:	For sea ice identification, coastal wind field measurement, wave slope measurement
Shipping:	For ship detection and classification
Coastal Zone:	For shoreline detection, substrate mapping etc.

APPLICATIONS

Agriculture

Satellites and airborne images are used as mapping tools to classify crops, examine their health and viability as well as to monitor farming practices. Agricultural applications of remote sensing include the following:

- i. Crop type classification
- ii. Crop condition assessment
- iii. Crop yield estimation
- iv. Mapping of soil characteristics
- v. Mapping of soil management practices
- vi. Compliance monitoring (farming practices)

Background Information

Crop mapping and identification is important for a number of reasons: to prepare an inventory of what will grow in certain area and when; for the purpose of forecasting grain supply (yield prediction), crop production statistics, mapping soil productivity, factors influencing crop tree, assessment of crop damage due to storms and drought and monitoring farming activity. Hence, remote sensing provides common data collection and information extraction strategies.

Remote sensing offers an efficient and reliable means of collecting the information required to map crop type and acreage. It can provide structure information about the health of vegetation. Radar is sensitive to the structure, alignment, and moisture content of the crop and thus provides complementary information of the optical data.

Forestry

Forestry applications remote sensing includes the following:

- i. **Reconnaissance Mapping:** This includes forest cover updating, depletion monitoring and measuring bio-physical properties of forest stands.
- ii. **Commercial Forestry:** Resource management agencies are inventory and mapping applications by collecting harvest information updating of inventory information for timber supply; broad forest type, vegetation density and bio-mass measurement.
- iii. **Environmental Monitoring:** Monitoring the quantity, health and density of earth's forests i.e. deforestation, species inventory, water shed protection and coastal protection; forest health and vigor.

Geology:

The applications of remote sensing in geology include:

- i. Surficial deposit/bedrock mapping
- ii. Lithological mapping
- iii. Structural mapping
- iv. Sand and gravel exploration/exploitation
- v. Mineral exploration
- vi. Hydrocarbon exploration
- vii. Environmental geology
- viii. Geo-botany and baseline infrastructure
- ix. Sedimentation mapping and monitoring
- x. Event mapping and monitoring
- xi. Geo-hazard mapping
- xi. Planetary mapping

Hydrology

Study of water on the Earth's surface, whether flowing above ground, frozen in ice or snow; or retained by soil.Examples of hydrological applications are:

- i. Wetlands mapping and monitoring
- ii. Soil moisture estimation
- iii. Snow pack monitoring/delineation
- iv. Measuring snow thickness
- v. Determining snow water equivalent
- vi. River and lake ice monitoring
- vii. Drainage basin mapping and water shed modeling
- viii.Irrigation canal leakage detection
- ix. Irrigation scheduling

Oceans and Coastal Monitoring

The ocean not only provide valuable food and biophysical resources, they also serves as transportation routes, crucially important in weather system formation and CO₂ storage and are important link on earth's hydrological balance. Coastline and environmentally sensitive interfaces between the ocean and land, and respond to changes brought about by economics development and changing land – use patterns.

Oceans applications of remote sensing include the following:

- i. Ocean pattern identification in current, regional circulation pattern, shears
- ii. Storm forecasting: wind and wave retrieved
- iii. Fish stock and marine mammal assessment: water temperature monitoring, water quality and ocean productivity; aquaculture inventory and monitoring.
- iv. Oil Spill: Mapping and predicting oil spill extent and drift strategies support for oil spill emergency response recession. Identification of natural oil seepage arrestor explanation.
- v. Shipping: Navigation routing, traffic density studies, operational fisheries surveillance, near shore mapping.
- vi. Intertidal Zone: Tidal and storm effects delineation of the land/water interfacemapping shoreline vegetation mapping, human activity/impact