

SECTION 1: INTRODUCTION

In this lesson, student should be able to learn

- the building blocks of a communication system
- the types of communication
- analog communication and digital communication
- transmission impairments
- technology used in communication system.

Discussion: The objective of any telecommunication is to facilitate communication between people who may be closer or located in different corners of the world. The information to exchange can be in different form e.g. text, graphics, voice or videos. In broadcasting information is sent from a central location and people just receive the information. It is not only people, devices may communicate, PC to renter, camera to PC.

1.1 Basis Telecommunication System

The basic principle o all types of communication are the same. The figure below shows a simple telecom system.

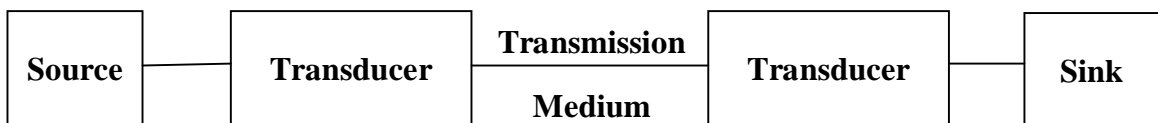

In an electrical communication system, at the transmitting side, a transducer converts the real-life information into an electrical signal. At the receiving side, a transducer converts the electrical signal back into real-life information. For example if two people want to talk to each other using this system, the transducer is the microphone that converts the sound waves into equivalent electrical signals. At the receiving end, the speakers convert the electrical signal into acoustic waves. The public address system used in an auditorium is an example of a simple communication system.

COURSE CODE:- CSC 417
COURSE TITLE:- INFORMATION & COMMUNICATION THEORY

The problem with this system is as the electrical signal passes through the transmission medium, the signal gets attenuated. In addition, the transmission medium introduces noise, and as a result, the signal gets distorted.

The noise cannot be eliminated. So the problem is overcome by amplifying the signal and the noise that is added to the actual signal containing the information.

Amplification does not solve the problem particularly when the system has to cover larger distances.

The objective of designing a communication system is for the electrical signal at the transmitting end to be reproduced at the receiving end with minimal distortion. To achieve this, different techniques are used, depending on issues such as type of data, type of communication medium, distance to be covered and so forth.

Different examples of Telecommunication system

- (a) **Communication between two computers:** The computer output electrical signals (through serial port, for example) and hence there is no need for a transducer. The data can be passed through the communication medium to the other computer if the distance is small (less than 100 meters).
- (b) A communication system in which two PCs communicate with each other over a telephone network. In this system, a new device called a Modern (Modulator-Demodulator) is introduced at both ends. The PCs send signals, which the modern converts into analog signals and transmits through the medium (copper wires). At the receiving end, the modern converts the incoming analog signal into digital form and passes it on to the PC.
- (c) In the case of a radio communication system for broadcasting audio program, the electrical signal is transformed into a high-frequency signal and sent through the air free space. A radio transmitter is used to do this. A reverse of this information –

COURSE CODE:- CSC 417
COURSE TITLE:- INFORMATION & COMMUNICATION THEORY

converting the high frequency signal into an audio signal – is performed at the receiving station. Since it is a broadcasting system, many receivers can receive the information.

In a communication system on which two person communicate with two other located somewhere else, but only one communication link, the voice signals need to be combined. The two voice signals cannot be mixed directly because it will not be possible to separate them at the receiving end. There is need to multiplex the two signals, using special techniques.

In a mobile communication system, a radio channel has to be shared by a number of user. Each user has to use the radio channel for a short time during which he has to transmit this data and then wait for his ext turn. This mechanism of sharing the channel is known as multiple access. Hence, depending on the type of communication, the distance to be covered etc. a communication system will consist of a number of elements, each element carrying out a specific function. Some important elements are;

- (i) **Multiplexer:** Combines the signals from different sources to transmit on the channel. At the receiving end, a demultiplexer is used to separate the signals.
- (ii) **Multiple access:** When two or more users share the same channel, each user has to transmit his signal only at a specified time or using specific frequency band.
- (iii) **Error detection and correction:** If the channel is using, he received data will have errors. Detection, and if possible correction, of the errors has to be done at the receiving end. This is done through a mechanism called channel coding.
- (iv) **Source coding:** If the channel has a lower bandwidth than the input signal bandwidth, the input signal has to be processed to reduce its bandwidth so that it can be accommodated on the channel.

COURSE CODE:- CSC 417
COURSE TITLE:- INFORMATION & COMMUNICATION THEORY

- (v) **Switching:** If a large number of users has to be provided with communication facilities, as in a telephone network, the users are to be connected based on the numbers dialed. This is done through a mechanism called switching.
- (vi) **Signaling:** In a telephone network, when you dial a particular telephone number, you are telling the network who you want to call. This is called signaling information. The telephone switch (or exchange) will process the signaling information to carry out the necessary operations for connecting to the called party.

1.2 TYPES OF COMMUNICATION

Based on the requirements, the communication can be of different types:

- (i) **Point-to-point Communication:** In this type, communication takes place between two end points. For instance, in the case of voice communication using telephones, there is one calling party and one called party. Hence, the communication is point-to-point.
- (ii) **Point-to-Multipoint Communication:** In this type of communication, there is one sender and multiple recipients. For example, in voice conferencing, one person will be talking but many others can listen. The message from the sender has to be multilast to many others.
- (iii) **Broadcasting:** In a broadcasting system, there is a central location from which information is sent to many recipients, as in the case of audio or video broadcasting. In a broadcasting system, the listeners are passive, and there is no reverse communication path.
- (iv) **Simplex Communication:** In simplex communication, communication is possible only in one direction. There is one sender and one receiver in the system. The sender and receiver cannot change roles.

- (v) **Half-duplex Communication:** Half-duplex communication is possible in both direction between two entities (computers or person), but one at a time. A walkie-talkie uses this approach. The person who wants to talk presses a talk button on his handset to start talking, and the other person's handset will be in receive mode. When the sender finishes he terminates it with an over message. The other person can press the talk button and start talking. These types of systems require limited channel bandwidth, so they are low cost system.
- (vi) **Full-duplex communication:** In a full-duplex communication system, the two parties – the caller and the called – can communicate simultaneous as in a telephone system. However, note that the communication system allows simultaneous transmission of data, but when two person talk simultaneously there is no effective communication. The ability of the communication system to transport data in both direction defines the system as full duplex.

Depending on the type of information transmitted we have voice communication, data communication, fax communication, and video communication system. When various type of information are clubbed together we talk of multimedia communication.

With the advent of digital communication and “convergence technologies”, this distinction is slowly disappearing and multimedia is becoming the order of the day.

1.3 TRANSMISSION IMPAIRMENTS

While the electrical signal is traversing over the medium, the signal will be impaired due to various factors. These transmission impairment can be classified into 3 types:

- a) Attenuation distortion
- b) Delay distortion
- c) Noise

COURSE CODE:- CSC 417
COURSE TITLE:- INFORMATION & COMMUNICATION THEORY

The amplitude of the signal wave decreases as the signal travels through the medium. This effect is known as attenuation distortion.

Delay distortion occurs as a result of different frequency components arriving at different time in the guided media such as result copper wire or coaxial cable.

Noise can be divided into 4 but to discuss 2

Cross talk: Unwanted coupling between signal paths is known as cross talk. In the telephone network, this coupling is quite common. As a result of this, other conversation are heard. Cross talk is eliminated by using approximate design techniques.

- **Impulse noise:** This is caused by external electromagnetic disturbance such as lighting. This noise is unpredictable. When the signal is traversing the medium, impulse noise may cause sudden bursts of errors. This may cause a temporary disturbance in voice communication. For data communication, appropriate methods need to be devised whereby the lost data is retransmitted.

1.4 ANALOG VERSUS DIGITAL TRANSMISSION

The electrical signal output from a transducer such as microphone or a video camera is a analog signal, that is, the amplitude of the signal varies continuously with time. Transmitting this signal (with necessary transformations) to the receiving end results in analog transmission.

The output of a computer is a digital signal. The digital signal has a fixed number of amplitude levels. For instance, binary 1 can be represented by one voltage level (say 5 volt) and binary 0 can be represented by analog level (say 0 volt). The voice and video signals (output of the transducer) are always analog.

Analog signal is converted to digital format through analog digital conversion.

COURSE CODE:- CSC 417
COURSE TITLE:- INFORMATION & COMMUNICATION THEORY

Digital transmission is much more advantageous than analog transmission because digital systems are comparatively immune to noise. The advantages of digital systems are.

- i) More reliable transmission because only discrimination between ones and zeros is required.
- ii) Less costly implementation because of the advances in digital logic chips.
- iii) Ease of combining various of signals (voice, video etc)
- iv) Ease of developing secure communication system. All the newly developed communication systems are digital system. Only in broadcasting application is analog communication used extensively.

Assignment

1. Write a program to generate a bit stream of 1s and 0s.
2. Write a report on the history of telecommunication, listing the important milestones in the development of telecommunication technology.

Class Test

Differentiate between simplex communication and full-duplex communication

SECTION 2: INFORMATION THEORY

In this lesson, student would learn;

- The Requirements of a communication system.
- The Building blocks of a communication as proposed by Shannon.
- Entropy and channel capacity
- Shannon's source coding Theorem and Channel Coding Theorem.

2.1 REQUIREMENTS OF A COMMUNICATION SYSTEM

The requirement of a communication system is to transmit the information from the source to the destination without errors, in spite of the fact that noise is always introduced in the communication medium.

2.1.1 The Communication System

The figure below shows a generic communication system.

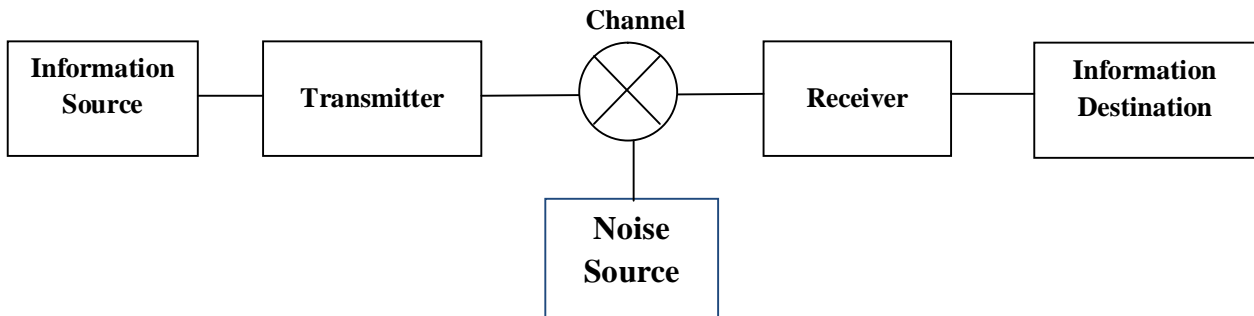

The information source produces symbols (such as English letters, speech, video etc) that are sent through the transmission medium by the transmitter. The communication medium introduces noise, and so errors are introduced in the transmitted data. At the receiving end, the receiver decodes the data and gives it to the information destination.

Example 2.1

As an example, consider the information source that produces two symbols A and B. The transmitter codes the data into a bit stream. For examples, A can be coded as 1 and B as 0. The stream of 1s and 0s is transmitted through the medium. Because of noise, 1 may become 0 and 0 may become 1 at random places as illustrated below;

Symbols produced:	A	B	B	A	A	A	B	A	B	A
Bit stream produced:	1	0	0	1	1	1	0	1	0	1
Bit stream received:	1	0	0	1	1	1	1	1	0	1

At the receiver, one bit is received in error. How to ensure that the received data can be made error free is now provided by Shannon.

Hence the generic communication system is now expanded as shown below.

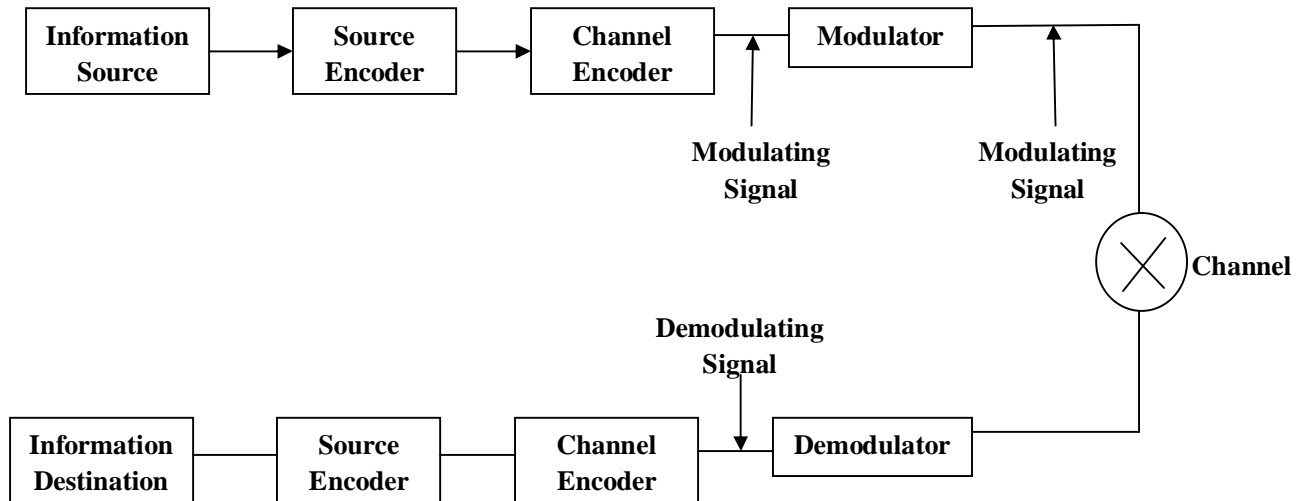

Fig 2.1: Generic communication system as proposed by Shannon.

In figure 2.1, the information source produces the symbols that are coded using two types of coding: source encoding and channel encoding and then modulated and sent over the medium. At the receiving end, the modulated signal is demodulated, and the inverse operations of channel encoding and source encoding (channel decoding and source decoding) are performed. Then the information is presented to the information sink. Each block is explained as

- I. **Information Source:** The information source produces the symbols. If the information source is for example, a microphone, the signal is in analog is in digital form (a set of symbols).

The theory

Let S be the source and P be the probability associated with it; that is for q source

S_1, S_2, \dots, S_q : Source alphabet

P_1, P_2, \dots, P_q : Probability

Facts:

- (1) The information content $I(S_i)$ is inversely proportional to the probability of occurrence, P_i .

$$\text{i.e. } I(S_i) \propto \frac{1}{P_i} \quad (1)$$

- (2) Recall from the law of probability distribution, if 2 random variables X and Y are stochastically dependent then

$$P(XY) = P(X)P(Y)$$

Thus, the information content from two different independent symbols is the sum of the information content from each separately i.e. from (1)

$$I(S_i) = \log\left(\frac{1}{P_i}\right) = -\log P_i \quad (2)$$

For 2 different independent symbols; we have

$$\begin{aligned} I(S_1, S_2) &= I(S_1) + I(S_2) \\ &= \log\left(\frac{1}{P_1}\right) + \log\left(\frac{1}{P_2}\right) \quad (3) \end{aligned}$$

Since $\log_a a + \log_b C = \log_b aC$

then (3) becomes

$$\log\left(\frac{1}{P_1 P_2}\right) = I(S_1, S_2)$$

II. Source Encoder

The source encoder converts the signal produced by the information source into a data stream. If the input signal is analog, it can be converted into digital form using analog-to-digital converted. If the input to the source encoder is a stream of symbols, it can be converted into a stream of 1's and 0s using some type of coding mechanisms.

For instance if the source produces the symbols A and B, A can be coded as 1 and B as 0.

COURSE CODE:- CSC 417
COURSE TITLE:- INFORMATION & COMMUNICATION THEORY

Source encoding is done to reduce the redundancy in the signal. The two types of source coding techniques are lossless coding and lossy coding.

In lossless coding technique, there is no loss of information e.g. when a computer file is compressed using a compression technique for instance WinZip. Compression is the process of coding to effectively reduce the total number of bits needed to represent certain information! It is the process of making data representation smaller, in order to decrease the data's bandwidth and storage requirement. Compression is a major contribution to data communication. It reduces the cost and resources necessary for transmission by reducing both the transmission time and network payload for the same amount of information. It is achieved by redundancy; extra information that is necessary is removed.

In lossy coding technique, some information is lost while doing the source coding. As long as the loss is not significant, the data can still be tolerated. When an image is converted into JPEG format, the coding is lossy coding because some information is lost. Most of the technique used for voice image and video coding are lossy coding techniques.

Take home: List out the techniques/algorithm for both lossy and lossless compression.

III. Chanel encoding

To decode the information correctly, even if errors are introduced in the medium, there is need to put some additional bits in the source-encoded data so that the additional information can be used to detect and correct the errors. This process of adding bits is done by channel encoder.

In channel encoding, redundancy is introduced so that the receiving end, the redundant bits can be used for error detection or error correction.

COURSE CODE:- CSC 417
COURSE TITLE:- INFORMATION & COMMUNICATION THEORY

IV. Modulation: This is the process of transforming the signal so that the signal can be transmitted through the medium.

V. Demodulation: The demodulator performs the inverse operation of the modulator

VI. Chanel decoder

The channel decoder analyzes the received bit stream and detects and corrects the errors if any, using the additional data introduced by the channel encoder.

VII. Source decoder

The source decoder converts the bit stream into the actual information. If the analog-to-digital conversion is done at the source encoder, digital-to-analog conversion is done at the source decoder.

If the symbols are coded into 1s and 0s at the source encoder, the bit stream is converted back to the symbols by the source decoder.

VIII. Information Destination/Sink: The information sink absorbs the information.

2.2 ENTROPY OF AN INFORMATION SOURCE

In information theory, an information source is a probability distribution, i.e., a set of probabilities assigned to a set of outcomes. This reflects the fact that the information contained in an outcome is determined not only by the outcome but by how uncertain it is. An almost certain outcome contains little information.

Example

Consider a rain forest in the Sahara desert. This forecast is an information source. The information source has two outcomes; rain or no-rain. Clearly, the outcome no-rain contains little information; it is a highly probable outcome. The outcome rain, however, contains considerable information, it is a highly improbable event.

COURSE CODE:- CSC 417
 COURSE TITLE:- INFORMATION & COMMUNICATION THEORY

Shannon proposed a formula to measure information. This information measure is called the entropy of the source. It is a measure of the amount of uncertainty in a probabilities choice system (S, P) (the choice, choice, S together with its sets of probabilities).

If a source produces N symbols and if all the symbols are equally likely to occur, the entropy of the source is given by

$$H = \log_2 N \text{ bits/symbol}$$

For example, assume that a source produces the English letters (A to Z and space, totally 27, as symbols), and all these symbols will be produced with equal probability. In such a case, the entropy is

$$\begin{aligned} H &= \log_2 27 \\ &= 4.75 \text{ bits/symbol} \end{aligned}$$

The information source may not produce all the symbols with equal probability. For instance, in English the letter "E" has the highest frequency (and hence highest probability of occurrence), and the other letters occur with different probabilities in general if a source produces i^{th} symbol with or probability of $P(i)$, the entropy of the source is given by

$$H(\quad) = -\sum P(i) \log P(i)$$

It can be defined as the average information content over the whole alphabet of symbols that is

$$\begin{aligned} H_r(S) &= \sum P_i \log_r \left(\frac{1}{P_i}\right) \quad \text{-----} \quad (4) \\ &= \sum P_i \log_r (P_i)^{-1} \\ &= -\sum_{i=1}^q P_i \log_r (P_i)^{-1} \end{aligned}$$

This can be represented as

$$H_r(S) = H_2(S) \log_r 2 \quad \text{-----} \quad (5)$$

To show that (4) and (5) are equal

From (5) $H_2(S) \log_r 2$

$$\sum P_i \log_2 \left(\frac{1}{P_i} \right) \log_2 \dots \dots \dots (7)$$

Recall $\log_b a = \frac{\log_c a}{\log_c b}$

from (7) we have

$$\log_2 \left(\frac{1}{P_i} \right) = \frac{\log_r \left(\frac{1}{P_i} \right)}{\log_r (2)}$$

\Rightarrow (7) becomes

$$\begin{aligned} & \sum \frac{P_i \log_r \left(\frac{1}{P_i} \right)}{\log_r 2} \log_r 2 \\ & = \sum_{c=1}^q P_i \log_r \left(\frac{1}{P_i} \right) \dots \dots \dots \text{Proved} \end{aligned}$$

Entropy is a function of the probability distribution P_i and does not involve S_i . Its unit of measurement is bits/symbols, hence the base, $r = 2$.

Class work

- 1) A source produces two symbols A and B with probabilities of 0.6 and 0.4 respectively. Calculate the entropy of the source.

$$\begin{aligned} H &= - \sum P_i \log P_i \\ &= -(0.6 \log_2 0.6 + 0.4 \log_2 0.4) \\ &= 0.970 \text{ bits/ symbol} \end{aligned}$$

- 2) A source produces 42 symbols with equal probability. Calculate the entropy of the source.

$$\begin{aligned} H &= \log_2 42 \text{ bits/symbol} \\ &= 5.55 \text{ bits/symbol} \end{aligned}$$

- 3) Consider a source that produce four symbols with probabilities of $\frac{1}{2}, \frac{1}{4}, \frac{1}{8}$ and $\frac{1}{8}$ and all symbols are independent of each other. Calculate the entropy.

$$H = \sum P_i \log P_i$$

COURSE CODE:- CSC 417
 COURSE TITLE:- INFORMATION & COMMUNICATION THEORY

$$= \left\{ \frac{1}{2} \log_2 \frac{1}{2} + \frac{1}{4} \log_2 \frac{1}{4} + \frac{1}{8} \log_2 \frac{1}{8} + \frac{1}{8} \log_2 \frac{1}{8} \right\} \text{ OR}$$

$$H = \sum P_i \log \frac{1}{P_i}$$

$$= \frac{1}{2} \log_2 2 + \frac{1}{4} \log_2 4 + \frac{1}{8} \log_2 8 + \frac{1}{8} \log_2 8$$

$$= \frac{1}{2} + \frac{2}{4} + \frac{3}{8} + \frac{3}{8}$$

$$1 + \frac{3}{4} = \frac{7}{4} \text{ bits/symbol.}$$

4) Prove that for a certain vent $H(X) = 0$

2.2.1 Properties of Entropy

Recall from Probability Distribution Theory

Let X and Y be 2 independent random variables

then $P(XY) \neq P(X)P(Y)$ _____ Joint Distribution

$$P(X) = \sum_{y_i \in Y} P(X, Y = y_i) \Rightarrow \text{Marginal distribution}$$

$$P(X/Y) = \sum_{y_i \in Y} P(X, Y = y_i) P(X, Y = y_i) \Rightarrow \text{Conditional distribution}$$

By Baye's rule

$$P(X, Y) = P(X/Y) P(Y)$$

$$P(Y, X) = P(X)$$

(1) If (S_1, P_1) and (S_2, P_2) are two probabilistic choice. This implies that entropy depends only on the probability distribution but not on the nature of the possibilities in the choice system.

(2) $H(P_1, P_2, \dots, P_n) = H(P_1, P_2, \dots, P_n, 0)$

From the convention $0, \log 0 = 0$. It says that possibilities with various probabilities are irrelevant to the amount of uncertainty.

(3) $H(X) \geq 0$ with equality iff $P_i = 1$

(4) Joint entropy

COURSE CODE:- CSC 417
 COURSE TITLE:- INFORMATION & COMMUNICATION THEORY

$$H(X, Y) = \sum_{x \in X} \sum_{y \in Y} P(x, y) \log \frac{1}{P(x, y)}$$

(5) Conditional Entropy

$$H\left(\frac{X}{Y}\right) = - \sum_{y_i \in Y} P(Y = y_i) H\left(\frac{X}{Y} = y_i\right) \quad (11a)$$

Example: to show further the properties

For a set of possible message $X = (x_1, x_2, \dots, x_N)$ with equal probability $\{P: P_i = P \text{ for } i = 1, \dots, N\}$

$$\text{i.e. } P = \frac{1}{N} \quad \{Dice = \frac{1}{6}\}$$

$$H(X) = - \sum P \log P$$

$$= - \sum \frac{1}{N} \log \frac{1}{N}$$

$$\Rightarrow H(x_i, x_j) = - \sum_{i,j=1} \frac{1}{N^2} \log_2 \frac{1}{N^2}$$

$$= - \sum \frac{1}{N^2} \log_2 N^{-2}$$

$$= \sum \frac{1}{N^2} \log_2 N^2$$

$$= \log_2 N^2$$

$$= 2 \log_2 N$$

$$= \log_2 N + \log_2 N$$

i.e. for two symbols with equal probabilities

$$H(x_i, x_j) = \log_2 N + \log_2 N$$

Show that $H(X, Y) \leq H(X) + H(Y)$

Consider two choice system S_1 and S_2 and the associated system of independent choices.

$$S_1 x S_2 = \{(e_{1,1}, e_{2,1})(e_{1,1}e_{2,2}) \dots (e_{1n}e_{2n})\}.$$

By affecting probabilities $P_{i,j}$ to the compound choice $(e_{1i}e_{2j})$ this system of independent choices can be extended to a compound probabilistic choice system $(S_1 \times S_2, P)$ where $P = \{P_{i,j}; i = 1 \dots n, j = 1 \dots m\}$

$$\Rightarrow \sum_{i=1}^m \sum_{j=1}^m P_{i,j} = 1 \quad 0 \leq P_{i,j}$$

Let x be associated with the system (S_1, P_1) and Y with the system (S_2, P_2) . The pair of variables (X, Y) is then associated with the compound probabilistic system $(S_1 \times S_2, P)$.

Recall Two r.v X and Y are independent iff

$$P_{x,y}(x, y) = P(x) \cdot P(y)$$

There are 3 entropies associated with the 3 probabilistic choice system X, Y and (X, Y)

$$\text{i.e. } H(X, Y) = - \sum_{x \in S_1} \sum_{y \in S_2} P_{x,y}(x, y) \log P_{x,y}(x, y)$$

$$H(X) = - \sum_{x \in S_1} P_x(x) \log P_x(x)$$

$$H(Y) = - \sum_{y \in S_2} P(y) \log P(y)$$

This theorem can be used to show that

$$H(X, Y) \leq H(X) + H(Y)$$

$$H(X) + H(Y)$$

$$= - \{ \sum P(x) \log P(x) + \sum P(y) \log P(y) \}$$

$$= - \{ \sum \sum P(x, y) \log(P(x) + \sum \sum P(x, y) \log P(y)) \}$$

$$= - \{ \sum_x \sum_y P(x, y) \log P(x) \cdot P(y) \}$$

From this lemma

$$\sum P(i) \log q(i) \leq \sum P(i) \log P(i)$$

$$H(X) + H(Y) \geq -(\sum \sum P(x, y) \log P(x, y))$$

$$\text{i.e. } -\{ \sum_x \sum_y P(x, y) \log P(x) \cdot P(y) \} \geq -\{ \sum \sum P(x, y) \log P(x, y) \}$$

$$\text{i.e. } H(X, Y) \leq H(X) + H(Y)$$

Example

Given a compound system of independent choices

$$S_1 \times S_2 = \{e_{11}, e_{2,1}\} (e_{11}e_{22}) (e_{12}e_{21}), (e_{12}e_{22})\}$$

$$P = \{0.5, 0.1, 0.3, 0.1\}$$

and two random variables (X, Y) associated with (S₁, S₂, P) with the single choice system identified as

$$S_1 = \{e_{11}, e_{12}\}, \quad S_2 = \{e_{21}, e_{22}\}$$

$$\text{with } P_1 = \{0.6, 0.4\} \text{ and } P_2 = \{0.8, 0.2\}$$

the entropies are now calculated as

$$\begin{aligned} H(X, Y) &= - \sum \sum P(x, y) \log P(x, y) \\ &= -0.5 \log 0.5 - 0.1 \log 0.1 - 0.3 \log 0.3 - 0.1 \log 0.1 \\ &\simeq 1.6855 \text{ bit} \end{aligned}$$

$$\begin{aligned} H(X) &= - \sum P(x) \log P(x) \\ &= -0.6 \log 0.6 - 0.4 \log 0.4 \\ &\simeq 0.9710 \text{ bit} \end{aligned}$$

$$\begin{aligned} H(Y) &= - \sum P(y) \log P(y) \\ &= -0.8 \log 0.8 - 0.2 \log 0.2 \\ &\simeq 0.7219 \text{ bit} \end{aligned}$$

which clearly shows the proof $H(X, Y) \leq H(X) + H(Y)$

For two variables X, and Y. Suppose the value of one variable say Y = y is observed. How does this affect the uncertainty concerning variable X?

This observation changes the distribution P(x) to the conditional distribution P_{x/y}(x, y) defined as

$$P_{x/y}(x, y) = \frac{P_{X,Y}(x, y)}{P_Y(y)} \text{ ----- } *$$

Therefore, the conditional entropy of X given Y-y is given as

$$H(X/Y = y) = - \sum_x \frac{P_x}{y}(x, y) \log P_{x/y}(x, y)$$

i.e. $H(X/y) = - \sum P_{x/y}(x, y) \log P_{x/y}(x, y)$ _____**

Note however, that if the two variables are independent then we have $P_{\frac{x}{y}}(x, y) = P_x(x)$ for

every x and y .

In this case

$$H(X/Y) = - \sum_x P_x(x) \log P_x(x) = H(x)$$

The uncertainty in X does not change, when a variable Y which is independent of X is observed.

Example 2 on Conditional Entropy

Given $P_{X,Y}(0,1) = P_{X,Y}(1,0) = P_{X,Y}(0,0) = 1/3$

$$P_{X,Y}(1,1) = 0, P_x(0) = P_Y(0) = 2/3$$

$$P_x(1) = P_Y(1) = 1/3.$$

Hence $H(X/Y) = - \sum P_{x/y}(x, y) \log P_{x/y}(x, y)$

$$H\left(\frac{X}{Y} = 0\right) = - P_{x/y}(0,0) \log P_{x/y}(0,0) - P_{x/y}(1,0) \log P_{x/y}(1,0)$$

$$= \frac{P_{X,Y}(0,0)}{P_Y(0)} \log \frac{P_{X,Y}(0,0)}{P_Y(0)} - \frac{P_{X,Y}(1,0)}{P_Y(0)} \log \frac{P_{X,Y}(1,0)}{P_Y(0)}$$

$$= - \frac{1/3}{2/3} \log \frac{1/3}{2/3} - \frac{1/3}{2/3} \log \frac{1/3}{2/3}$$

$$= -5.5 \log 0.5 - 0.5 \log 0.5$$

$$= 1$$

$$\begin{aligned}
 H(X|Y=1) &= \frac{P_{X,Y}(0,1)}{P_Y(1)} \log \frac{P_{X,Y}(0,1)}{P_Y(1)} - \frac{P_{X,Y}(1,1)}{P_Y(1)} \log \frac{P_{X,Y}(1,1)}{P_Y(1)} \\
 &= \frac{1}{3} \log \frac{1}{3} - \frac{1}{3} \log \frac{1}{3} \\
 &= 0
 \end{aligned}$$

$$\begin{aligned}
 H(X) = H(Y) &= -\frac{2}{3} \log \frac{2}{3} - \frac{1}{3} \log \frac{1}{3} \\
 &= 0.9183
 \end{aligned}$$

$$\therefore H(X|Y=1) < H(X) < H(X|Y=0)$$

Property 5b: Expected Conditional Entropy

In addition to the conditional entropy of X given a particular observation Y = y, the expected conditional entropy of X given Y, which is the expected value of H(x | y) relative to y can be considered as

$$H(X|Y) = \sum_y P_Y(y) H(X|y)$$

Note that

$$P_{XY}(x,y) = P_{(y)} P_{x|y}(x,y)$$

Therefore, the expected conditional entropy is as follows:

$$H(X|Y) = \sum_y P_Y(y) H(X|y) \text{ _____ to expand } H_{(x|y)}$$

From **

$$\begin{aligned}
 H(X|Y) &= \sum_x \sum_y P_Y(y) P_{x|y}(x,y) \log P_{x|y}(x,y) \\
 &= - \sum_x \sum_y P_{X,Y}(x,y) \log \frac{P_{X,Y}(x,y)}{P_Y(y)} \text{ from *} \\
 &= - \sum_x \sum_y P_{X,Y}(x,y) (\log P_{X,Y}(x,y) - \log P_Y(y))
 \end{aligned}$$

$$\Rightarrow H(X|Y) = H(X,Y) - H(Y)$$

Thus, gives the theorem for a pair of r.v X and Y

$$H(X,Y) = H(Y) + H(X|Y)$$

This theorem says the uncertainty of a pair of variables can be considered as the result of a chaining, where the uncertainty of one of the variables is considered first, say Y and then add the (expected) conditional uncertainty of the second one given the first one.

It can start with any of the variable. Thus

$$H(X, Y) = H(X) + H(Y | X)$$

This says that the whole uncertainty in the system is composed of the uncertainty of the input signal H(X) and the transmission uncertainty over the channel H(Y/X)



Transmission channel

Example 2.2.1(b) On Expected Conditional Entropy

From example 2.2.1(a)

$$\begin{aligned}
 H(X|Y) &= P_Y(0)H(X|Y=0) + P_Y(1)H(X|Y=1) \\
 &= \frac{2}{3}(1) + \frac{1}{3}(0)
 \end{aligned}$$

COURSE CODE:- CSC 417
 COURSE TITLE:- INFORMATION & COMMUNICATION THEORY

$$= \frac{2}{3} \text{ bit}$$

$$H(X, Y) = -\log \frac{1}{3} \approx 1.5850 \text{ bit}$$

$$\text{Check : } H(X, Y) = H(Y) + H(X|Y)$$

$$H(X, Y) = -\sum \sum P(x, y) \log P(x, y)$$

	$H(Y) =$	0.9183
+	$H(X Y) =$	0.6667
	$H(X, Y)$	1.5850

=

$$-[P(0,0) \log P(0,0) + P(1,0) \log P(1,0) + P(0,1) \log P(0,1) + P(1,1) \log P(1,1)]$$

$$= -[\frac{1}{3} \log \frac{1}{3} + \frac{1}{3} \log \frac{1}{3} + \frac{1}{3} \log \frac{1}{3} + 0]$$

$$= -3 [\frac{1}{3} \log_2 \frac{1}{3}]$$

$$= -\log_2 \frac{1}{3} = \log_2 3 = \frac{\log 10^3}{\log 10^2} = \approx 1.5850 \text{ bit}$$

2.2.2 Mutual Information

Consider a communication channel, with X the input source and Y the output. By observing the output Y we expect a positive amount of information regarding the input X. Although in particular transmission, uncertainty about the input is increased, on average the observation of the output decreases uncertainty about the input.

Given a compound probabilistic choice system $(S_1 \times S_2, P)$ and the associated random variables X and Y, the mutual information between these 2 variables can be defined as the expected gain in information on one variable, obtained if the other is observed. It is also the difference between the sum of the individual entropies of the 2 variables and the actual entropy of the pair. This implies that mutual information is always non-negative i.e. $I(X, Y) \geq 0$ if the 2 variables X, Y are independent.

$$\text{i.e. } I(X, Y) = H(P(X)) - H(P(X|Y))$$

OR
$$I(X, Y) = H(X) - H(X|Y)$$

The goal is to formally quantify the reduction in uncertainty by examining the appropriate subtraction of entropies.

Illustration of Mutual Information

Using the Venn diagram

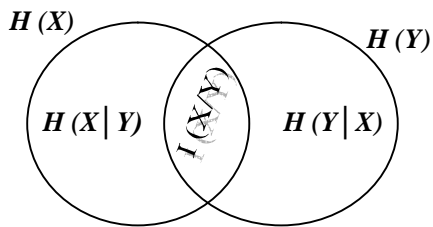

From this Venn diagram, mutual information can be defined $I(X|Y)$ or $I(X, Y)$

$$I(X|Y) = H(X) - H(X|Y)$$

$$I(X|Y) = H(Y) - H(Y|X)$$

$$I(X|Y) = H(X) + H(Y) - H(X, Y)$$

Because this formula is symmetric in X and Y, then $I(X|Y) = I(Y|X)$

So mutual information between X and Y is the same as between Y and X.

Example 2.2.2

Given the following probability distribution for transmitting information over a channel:

$$P(X) = \{\frac{1}{2}, \frac{1}{2}, 0\}$$

$$P(X|Y = 0) = \{1 - P, P, 0\}$$

$$P(X|Y = 1) = \{P, 1 - P, 0\}$$

Let the variable, $P = 0.2$ be the probability of incorrect transmission. Calculate the mutual information on this distribution.

Solution: $I(X, Y) = H(X) - H(X|Y)$

Given are Prob. of incorrect transmission i.e.

$Y = 1$ and of correct transmission, $Y = 0$

Calculate all the entropies

$$H(X) = - \sum P_i \log P_i$$

$$H(X) = -\left(\frac{1}{2} \log \frac{1}{2} + \frac{1}{2} \log \frac{1}{2} + 0\right)$$

$$= -\left[-\frac{1}{2} - \frac{1}{2}\right] = 1 \text{ bit/symbol}$$

$$H(X|Y = y) = -\sum P(Y = y_i) H(X|Y = y_i)$$

$$\text{From ** } H(X|Y = 1) = [P \log_2 P + (1 - P) \log_2 (1 - P) + 0]$$

$$= -[(1 - P) \log_2 (1 - P) + P \log_2 P]$$

$$= (1 - P) \log_2 (1 - P)^{-1} + P \log_2 P^{-1}$$

$$= (1 - P) \log_2 \left(\frac{1}{1 - P}\right) + P \log_2 \left(\frac{1}{P}\right) \text{----- (i)}$$

$$H(X|Y = 0) = -[(1 - P) \log_2 (1 - P) + P \log_2 P + 0]$$

$$= (1 - P) \log_2 \left(\frac{1}{1 - P}\right) + P \log_2 \left(\frac{1}{P}\right)$$

$$I(X|Y) = H(X) - [P(Y = 0)H(X|Y = 0) + P(Y = 1)H(X|Y = 1)]$$

$$= 1 - \left[\frac{1}{2} [(1 - P) \log_2 \left(\frac{1}{1 - P}\right) + P \log_2 \left(\frac{1}{P}\right)]\right]$$

$$+ \frac{1}{2} [(1 - P) \log_2 \left(\frac{1}{1 - P}\right) + P \log_2 \left(\frac{1}{P}\right)]$$

COURSE CODE:- CSC 417
 COURSE TITLE:- INFORMATION & COMMUNICATION THEORY

$$= 1 - \left[\frac{1}{2} \left[(1-P) \log_2 \left(\frac{1}{1-P} \right) + P \log_2 \left(\frac{1}{P} \right) \right] + \frac{1}{2} \left[(1-P) \log_2 \left(\frac{1}{1-P} \right) + P \log_2 \left(\frac{1}{P} \right) \right] \right]$$

$$= 1 - \left[(1-P) \log_2 \left(\frac{1}{1-P} \right) + P \log_2 \left(\frac{1}{P} \right) \right]$$

where P = 0.2

$$= 1 - \left[0.8 \log_2 \left(\frac{1}{0.8} \right) + 0.2 \log_2 \left(\frac{1}{0.2} \right) \right]$$

$$= 1 - [0.8 \log_2 1.25 + 0.2 \log_2 5]$$

$$= 1 - \left[0.8 \frac{\log_{10} 1.25}{\log_{10} 2} + 0.2 \frac{\log_{10} 5}{\log_{10} 2} \right]$$

$$= 1 - \left[0.8 \frac{0.0969}{0.30103} + 0.2 \frac{0.69897}{0.30103} \right]$$

$$= 1 - 0.8 (0.321895) + 0.2 (2.32193)$$

$$= 1 - (0.257516 + 0.4643856)$$

$$= 1 - 0.721902$$

$$= 0.278098$$

2.3.3 Kullback-Leibler Divergence

There is another important notion of information theory. Considered two probabilistic choice system, with the same choice set S, but different probability distributions. If X and Y are the corresponding r.v., this definition

$$K = (P_X, P_Y) = \sum_{x \in S} P_X(x) \log \frac{P_X(x)}{P_Y(x)} \text{ ****}$$

This is called the Kullback-Leibler divergence between X and Y. It is a kind of distance between the probability distribution of X and Y. it is also called the Relative entropy two distributions.

$$K = (P_X, P_Y) = 0 \text{ iff } P_X = P_Y$$

$$\text{and } K = (P_X, P_Y), K = (P_Y, P_X) \geq 0 \text{ _____ (?)}$$

from ***, we can show that (?) holds

$$K = (P_X, P_Y) = \sum P_X(x) \log P_X(x) - \sum P_X(x) \log P_Y(x)$$

From Lemma 1 in the note then

$$K = (P_X, P_Y) \geq 0$$

Example 2.2.3

$$\text{Given } P_X(0) = 0.2 \text{ and } P_X(1) = 0.8$$

$$P_Y(0) = 0.26 \text{ and } P_Y(1) = 0.74$$

$$\text{then } K(P_X, P_Y) = P_X(0) \log \frac{P_X(0)}{P_Y(0)} + P_X(1) \log \frac{P_X(1)}{P_Y(1)}$$

$$= 0.2 \log_2 \frac{0.2}{0.26} + 0.8 \log_2 \frac{0.8}{0.74}$$

$$\simeq 0.0143 \text{ bit}$$

Also,

$$K(P_Y, P_X) = P_Y(0) \log \frac{P_Y(0)}{P_X(0)} + P_Y(1) \log \frac{P_Y(1)}{P_X(1)}$$

$$= 0.26 \log_2 \frac{0.26}{0.2} + 0.74 \log_2 \frac{0.74}{0.8}$$

$$\simeq 0.015 \text{ bit} \Rightarrow K(P_X, P_Y) \neq K(P_Y, P_X)$$

Check example 1.32 in the textbook

2.3 SOURCE CODING

In a digital communication system, the aim of the designer is to convert any information into digital signal, pass it through the transmission medium, and at the receiving end, reproduce the digital signal exactly. To achieve this objective, two important requirements are;

1. To code any type of information into digital format. Note that the world in analog e.g. voice signals, images etc. There is need to devise mechanism to convert these analog

COURSE CODE:- CSC 417
COURSE TITLE:- INFORMATION & COMMUNICATION THEORY

signals into digital format. If the source produces symbols (such as A, B), there is need to convert these symbols into a bit stream. This coding has to be done efficiently so that the smallest number of bits is required for coding.

2. To ensure that the data sent over the channel is not corrupted. Noise introduced on the channels cannot be eliminated, hence there is need to introduce some special coding technique to overcome the effect of noise.

These two aspects have been addressed in source coding theorem and channel coding theorem.

2.3.1 Source Coding Theorem

The source coding theorem states that “the number of bits required to uniquely describe an information source can be approximated to the information content as closely as desired” Shannon theorem does not state the type of coding technique but puts a limit on the minimum number of bits required. *Engineers are striving to achieve the limit all these 50 > years. Consider a source that produces two symbols A and B with equal probability.

Table 1

Symbol	Probability	Code Word
A	0.5	1
B	0.5	0

For this coding, we require 1 bit/symbol. Now consider a source that produces these same two symbols, but instead of coding A and B directly, it can be coded as AA, AB, BA, BB.

The probabilities of these symbols with their associated codewords are shown here;

Table 2

Symbol	Probability	Code Word
AA	0.45	0
AB	0.45	10
BA	0.05	110
BB	0.05	111

In this case, there are different sizes of bits or each codeword. So the average number of bits required per symbol can be calculated using the formula

$$L = \sum_{i=1}^I P(i) l(i)$$

$$\text{where } I = |X|$$

That is, the average or expected length of codeword, denoted by L. where P(i) is the probability and l(i) is the length of the codeword.

from Table 2

$$L = [1*0.45 + 2*0.45 + 3*0.05 + 3*0.05]$$

$$= 1.65 \text{ bits/symbol.}$$

The entropy of the source is 1.469 bits/symbol.

So if the source produces the symbols in the following sequence:

A A BA BA AB BB

Then source coding gives the bit stream.

0 110 110 10 111

This coding scheme requires 1.65 bits/symbol. The coding mechanism taking the probabilities into consideration is a better coding technique. The theoretical limit of the number of bits/symbol is the entropy which is 1.469 bits/symbol. The entropy of the source provides the lower bound of the average codeword length of the source code i.e.

$$L(c) \geq \frac{H(X)}{\log_2 n}$$

where $P_i = n^{-li} \Rightarrow L(c) = H_n(x)$

where n is the size of the code alphabet.

Proof

$$\begin{aligned} H(x) &= -\sum_{i=1}^l P_i \log P_i \\ &= -\sum n^{-li} \log n^{-li} \\ &= \sum l i n^{-li} (\log n) \\ &= \log n \sum l i n^{-li} \end{aligned}$$

$$L(C) = \sum_{i=1}^l l i P_i = \sum l i n^{-li}$$

i.e. $H(x) \log_n L(c)$

$$\Rightarrow L(C) = \frac{H(x)}{\log n}$$

Only when $P_i = n^{-li}$

Example 2.3.1: Let X be a r.v. with the following distribution and codeword assignment

$$\begin{aligned} P(X = 1) &= 1/2; & C(1) &= 0 \\ P(X = 2) &= 1/4; & C(2) &= 10 \\ P(X = 3) &= 1/8; & C(3) &= 110 \\ P(X = 4) &= 1/8; & C(4) &= 111 \end{aligned}$$

Find (i) the mean information provided by the source X (ii) the expected length of codeword, C (i.e. the average number of bit used).

Solution

(i) The mean information i.e. the entropy, $H(x) = \sum P(x_i) \log_2 P(x_i)$

$$\begin{aligned} &= \frac{1}{2} \log \frac{1}{2} + \frac{1}{4} \log \frac{1}{4} + 2 \left(\frac{1}{8} \log \frac{1}{8} \right) \\ &= 1.75 \text{ bits/symbol} \end{aligned}$$

(ii) the expected length of codeword c , i.e. $L(C)$

$$\begin{aligned}
 L(C) &= \sum P(x) l(x) \\
 &= \frac{1}{2}(1) + \frac{1}{4}(2) + \frac{1}{8}(3) + \frac{1}{8}(3) \\
 &= \frac{1}{2} + \frac{1}{2} + \frac{3}{4} \\
 &= 1.75 \text{ bits}
 \end{aligned}$$

$$\begin{aligned}
 \Rightarrow L(C) &\geq \frac{H(x)}{\log_2 n} \\
 &\geq \frac{1.75}{\log_2 4} \geq \frac{1.75}{2} \\
 2.3 &\geq 0.875
 \end{aligned}$$

2.3.1.1 Classes of Codes

There are basic requirements for a useful symbol code.

First, any encoded string must have a unique coding.

Second, the symbol code must be easy to decode.

Thirdly, the code should achieve as much compression as possible (*i.e.* $L(C)$)

(1) Any encoded string must have a unique decoding. A code (x) is said to be non-singular if distinct elements in X map into different strings in F^* (where F is the set of finite length strings of symbols from q -ary alphabet, assume $F = \{0, 1, \dots, q-1\}$ for a q -ary alphabet ($C: X \rightarrow F^*$)).

$$\text{i.e. for } x, y \begin{matrix} x \rightarrow C(x) \\ y \rightarrow C(y) \end{matrix}$$

that is for any $x \neq y$, where $x, y \in X$ we have $C(x) \neq C(y)$

Non-singularity means that if a single value of X is transmitted, it can be uniquely decoded.

The extension of a code C is the mapping from finite length strings of X to finite length strings of F , defined by $C(x_1, x_2, \dots, x_n) = C(x_1), C(x_2), \dots, C(x_n)$

COURSE CODE:- CSC 417
COURSE TITLE:- INFORMATION & COMMUNICATION THEORY

e.g. if $C(a) = 00$ and $C(b) = 11$ then

$C(aa) = 00\ 00$, $C(ab) = 00\ 11$

A code is called uniquely decodable, if its extension is non-singular from the example 2.3.1 with the information given, any sequence of bits can be uniquely decoded e.g. 0110111100110 is 134213

(2) The symbol code must be easy to decode

A symbol code is easiest to decode if it is possible to identify the end of a codeword as soon as it arrives which means that no codeword can be a prefix of another codeword. {A word C is a prefix of another word d if a tail string the concatenation ct is identical to d.

e.g. 0 is a prefix of 010 and 011

Any encoded string in a uniquely decodable code has only one possible source string producing it. However, one may have to look at the entire string to determine even the first symbol in the corresponding source string. A code is said to be instantaneously decodable following each code word in any string of codewords can be decoded as soon as its end is reached. A code is called a prefix code or an instantaneous code if no codeword is a prefix of any other codeword.

Example 2.3.1(b)

If $C = \{0, 10, 110, 111\}$ then the string 010111111010 can be parsed as 0 10 111 110

10

In other to illustrate classes of codes, the table below illustrates the differences.

Table 3

	Singular	Non-singular but not uniquely decodable	Uniquely decodable but not instantaneous	Instantaneous
X				
1	0	0	10	0
2	0	010	00	10
3	0	01	11	110
4	0	10	110	111

Example 2.3.1 (c)

Consider some information source, U, the symbols of which are $U_1, U_2 = 2$ and U_3 and $U_4 = 4$ with the following probability distribution.

U_i	1	2	3	4
$P(U = U_i)$	0.5	0.25	0.125	0.125
$C(U_i)$	0	10	110	111

- I. Is this code instantaneously decodable?
- II. Encode the message 423312
- III. Decode the sequence 101101010

Solution

- (i) Any prefix code is instantaneously decodable and conversely any instantaneously decodable code is prefix code. This implies that the code is instantaneously decodable.
- (ii) 1423312
011110110110010
- (iii) 101101010

COURSE CODE:- CSC 417
 COURSE TITLE:- INFORMATION & COMMUNICATION THEORY
 = 2322

In order to construct instantaneous codes of minimum expected length to describe a given source, Kraft inequality appears as a sufficient condition.

2.3.1.2 Kraft Inequality Theorem

For any instantaneous code over an alphabet of size, q the codeword length $\ell_1, \ell_2, \dots, \ell_m$ must satisfy the inequality:

$$\sum_{i=1}^m q^{-\ell_i} \leq 1 \quad \dots\dots\dots (1) \text{ where } q \geq 2 \text{ for any binary alphabet}$$

Conversely, given a set of codeword lengths that satisfy this inequality, there is an instantaneous code with these word lengths.

i.e. always exists a prefix code C with precisely these codeword lengths, $\ell(x)$.

When equation (1) is satisfied with equality, the corresponding prefix code is called a complete code.

e.g. using these codewords $\{0, 10, 11\}$

$$\begin{aligned} \sum 2^{-\ell_i} &= 2^{-1} + 2^{-2} + 2^{-2} \\ &= 1/2 + 1/4 + 1/4 = 1 \\ &\Rightarrow \text{a complete code.} \end{aligned}$$

Kraft inequality shows when a prefix code exists and does not answer the question if a given code is indeed prefix-free code.

Proof:

Kraft inequality is proved by building a tree representation of all possible binary strings as

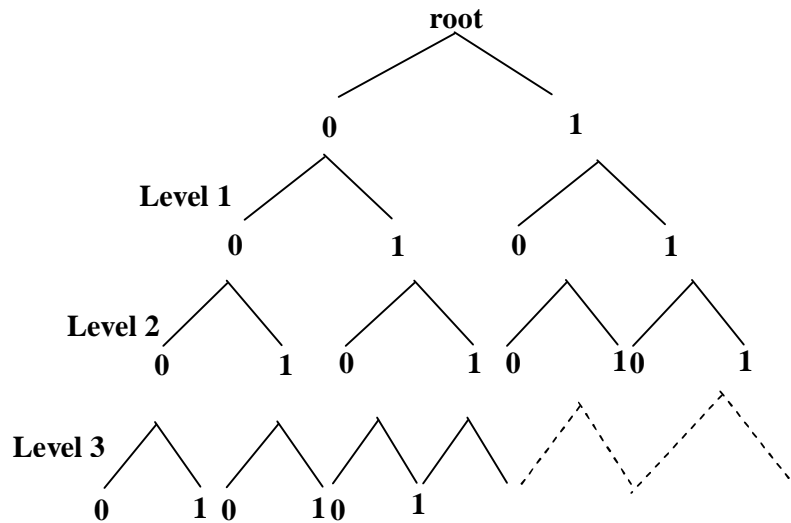

Theorem 1 (Kraft Inequality): Given a message set A . any prefix code C , characterized by a set of codeword length $\ell(x); x \in A$ satisfies the Kraft inequality.

$$\sum_{x \in A} \left(\frac{1}{2}\right)^{\ell(x)} \leq 1$$

Proof:

To prove this inequality, a tree representation of all possible binary strings, is built as

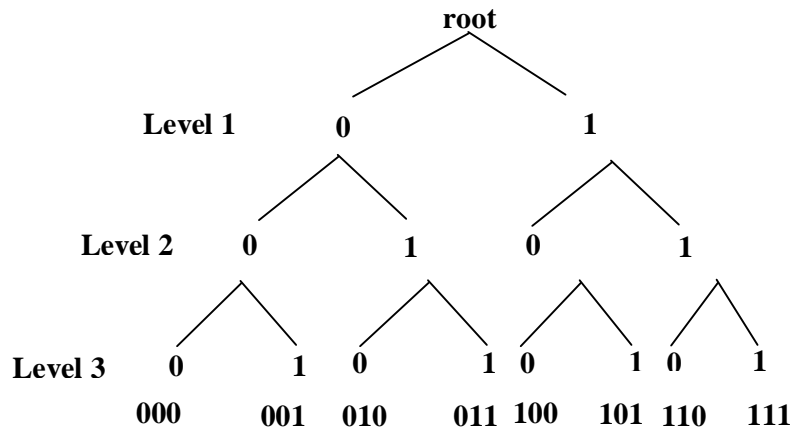

This tree extends downward towards infinity. To each branch point in this tree, a binary string is associated which simply represents all bits one runs into if one follows the directed

path from the directed path from the root to that particular branch point e.g. at level 1, we have the branch points 0 and 1, level 2 : 00, 01, 10, 11 and so on.

- At level n , the binary strings associated with the nodes are just the binary representations of the numbers, $0, 1, \dots, 2^n - 1$ e.g. for level 3 it is $2^3 - 1 = 7 \Rightarrow$ binary representation of $0, 1, \dots, 7$.
- Those strings that actually occur among the codewords of a prefix code C under consideration are marked with a \bullet (in the tree, the codewords occurring up to length 3 are 00, 01 and 1000).
- Since C is a prefix code we know that, once a branch point is selected to correspond to a codeword (marked by \bullet), there can be no other further down along the tree rooted in that particular branch point.
- Weights are associated with the branch points of the tree as follows, starting with weight 1 at the root. The two nodes at level 1 each carry weight $\frac{1}{2}$, the four nodes at level 2 each carry weight $\frac{1}{4}$, and so on
i.e. the 2^K nodes at level K each carry weight 2^{-K} . This construction ensures that irrespective of the level K ,
 - (i) the total weight of all 2^K nodes at that level adds up to 1.
 - (ii) The total weight of a subset set nodes which together form the complete set of descendants of a node at level $\ell < K$ (containing $2^{K-\ell}$ elements) adds up to $2^{-\ell}$
i.e. the weight of the originating node.
- Now at each level $n \geq 1$, one can divide the set of nodes into three disjoint groups:
 - (i) nodes that are blocked and may not be used for codewords because they are descendants of a node that has been used as a codeword $C(x)$ at a level weight adds up to $2^{-\ell(x)}$
 - (ii) nodes that are used as codewords at the level n .

(iii) nodes that are unused (and may not represent the first n bits of further codewords of length $m > n$).

(iv) labeling bitstrings $C_n \in \{0, 1\}$ and recalling that the weight $W(C_n)$ of a node associated with C_n (at level n) is $W(C_n) = 2^{-n}$, for all $n \geq 1$;

$$\Rightarrow \sum W(C_n) = \sum_{C_n: \text{blocked}} \left(\frac{1}{2}\right)^n + \sum_{C_n: \text{used}} \left(\frac{1}{2}\right)^n + \sum_{C_n: \text{unused}} \left(\frac{1}{2}\right)^n$$

$$= \sum_{x \in EA, \ell(x) < n} \left(\frac{1}{2}\right)^{\ell(x)} + \sum_{x \in EA, \ell(x) = n} \left(\frac{1}{2}\right)^{\ell(x)} + \dots$$

(of course $\ell(x) < n$) (at level 3, we have 3 bitstrings i.e.)

By omitting the weight of the unused nodes from the sum, we get

$$\forall n \geq 1 : \sum_{x \in EA, \ell(x) \leq n} \left(\frac{1}{2}\right)^{\ell(x)} \leq 1 \quad (\text{of course after remove blocked and unused})$$

This result follows immediately by taking the limit $n \rightarrow \infty$

$$\sum_{x \in EA} \left(\frac{1}{2}\right)^{\ell(x)} \leq 1$$

Conversely there is another theorem as Theorem 2: If a set of codeword length $\ell(x)$ satisfies the Kraft inequality, there is a corresponding prefix code having the $\ell(x)$ as codeword lengths.

Proof:

This is proved by explicit construction.

We first order the codeword length ℓ_1

i.e. $\ell(x_i)$ according to increasing length:

$$\ell_1 \leq \ell_2 \leq \ell_3 \leq \dots$$

Codewords are then constructed in terms of the binary tree drawn earlier (refers)

- Choose for the first codeword C_1 the leftmost branch point at level ℓ_1 in the tree.

COURSE CODE:- CSC 417
 COURSE TITLE:- INFORMATION & COMMUNICATION THEORY

That is $C_1 = 00 \dots 0$ (ℓ_1 zero's)

Then iterate

- If $\ell_{i+1} = \ell_i$ C_{i+1} is branch point to the right of C_i
- If $\ell_{i+1} > \ell_i$ C_{i+1} is leftmost available node at level ℓ_{i+1} (A branchpoint is available if it's not a descendant of a codeword used earlier and these blocked).
- $i \rightarrow i + 1$
- There is a concise algebraic representation of this iterative scheme in terms of arithmetic in base-2 representation viz.

$$C_1 = 0$$

$$C_{i+1} = 2^{(\ell_{i+1} - \ell_i)} \times (C_i + 1); i \geq 1$$

where it is understood that the binary representation of C_i uses ℓ_i bits – allowing as many leading zero's as necessary to achieve this, if $C_i > 2^{\ell_i} - 1$

- This construction could only fail, if we allocated a codeword to the right-most node at some level n at a stage where there are still codeword lengths waiting to get a codeword. In terms of the categorization of the codewords at level n , this means that they are all either blocked (by codewords assigned at levels higher up in the tree) or used and no unused ones are left (hence all nodes further down the tree would be blocked), so

$$\sum \left(\frac{1}{2}\right)^{\ell_i} = 1$$

$$i = \ell \leq n$$

Example 2.3.1.1(c): To illustrate the construction of prefix codes, choose the set

$$\{\ell_i\} = \{2, 2, 3, 3, 4, 4\}$$

Check for kraft inequality

$$\begin{aligned} \sum \left(\frac{1}{2}\right)^{\ell_i} &= \left(\frac{1}{2}\right)^2 + \left(\frac{1}{2}\right)^2 + \left(\frac{1}{2}\right)^3 + \left(\frac{1}{2}\right)^3 + \left(\frac{1}{2}\right)^4 + \left(\frac{1}{2}\right)^4 \\ &= 2 \left[\left(\frac{1}{2}\right)^2 + \left(\frac{1}{2}\right)^3 + \left(\frac{1}{2}\right)^4 \right] \\ &= 2 \left[\frac{1}{4} + \frac{1}{8} + \frac{1}{16} \right] = \frac{1}{2} + \frac{1}{4} + \frac{1}{8} \\ &= \frac{7}{8} \end{aligned}$$

This satisfies kraft inequality.

This is the construction code

$$\begin{aligned} C_1 &= 0 \\ C_{i+1} &= 2^{(\ell_{i+1} - \ell_i)} \times (C_i + 1) \end{aligned}$$

generates

	construction	result
	$C_1 = 0$	00
$i = 1$	$C_2 = 2^{(\ell_2 - \ell_1)} \times C_1 + 1$ $= 2^0 * 1 = 1$	01
$i = 2$	$C_3 = 2^{\ell_3 - \ell_2} \times C_2 + 1$ $= 2^{3-2} * 2 = 4$	100
$i = 3$	$C_4 = 2^{\ell_4 - \ell_3} \times C_3 + 1$ $= 2^{3-3} * 4 + 1 = 5$	101
$i = 4$	$C_5 = 2^{\ell_5 - \ell_4} \times C_4 + 1$ $= 2^{4-3} * 5 + 1 = 12$	1100
$i = 5$	$C_6 = 2^{\ell_6 - \ell_5} \times C_5 + 1$ $= 2^{4-4} * 13 = 13$	1101

This is a prefix code, with the required codeword lengths.

Example 2.3.1.1(ii) This example illustrates how the construction fails when the Kraft inequality is not satisfied. Choose $\{\ell_i\} = \{1, 2, 2, 2\}$.

$$\begin{aligned}\sum (1/2)^{\ell_i} &= 1/2 + 3(1/2)^2 \\ &= 5/4 > 1\end{aligned}$$

Construction given the correspond code

$C_1 = 0$	0
$C_2 = 2 * C_1 + 1 = 2$	10
$C_3 = C_2 + 1 = 3$	11
$C_4 = C_3 + 1 = 4$	$\equiv 100$ (not a 2. Bit string).

\Rightarrow a prefix code with codeword length $\{\ell_i\}$ violating the Kraft inequality cannot be constructed. Once C_3 is found, the rightmost node at level 2 has been reached. (C_3 consists only of 1's); the tentative C_4 constructed via the algebraic iteration scheme does not allow a 2-bit representation as required. Another way to see the failure of the construction is to note that C_2 is a prefix of the tentatively constructed C_4 !

2.4 Channel Capacity

Shannon introduced the concept of channel capacity, the limit at which data can be transmitted through a medium. The errors in the transmission medium depend on the energy of the signal, the energy of the noise and the bandwidth of the channel. Conceptually, if the bandwidth is high, more data can be pumped in the channel. If the signal energy is high, the effect of noise is reduced.

According to Shannon, the bandwidth of the channel and signal energy and noise energy are related by the formula:

COURSE CODE:- CSC 417
COURSE TITLE:- INFORMATION & COMMUNICATION THEORY

$$C = W \log_2(1 + S/N) \text{ where}$$

C is channel capacity in bits/second (bps)

W is bandwidth of the channel in Hz

S/N is the signal-to-noise power ratio (SNR)

SNR is measured in dB using the formula

$$(S/N)_{dB} = 10 \log (\text{Signal power/Noise power})$$

The value of the channel capacity obtained using this formula is the theoretical maximum.

As an example, consider a voice-grade line for which $W = 3100\text{Hz}$, $\text{SNR} = 30\text{dB}$ (i.e. the signal-to-noise ratio is 1000:1)

$$\begin{aligned} C &= 3100 \log_2 (1 + 1000) \\ &= 30,894 \text{ bps} \end{aligned}$$

So, we cannot transmit data at a rate faster than this value in a voice-grade line. An important point to be noted is that in the above formula, Shannon assume only thermal noise.

To increase C, can W be increased?

No, because increasing W increases noise as well, and SNR will be reduced.

To increase C, can SNR be increased?

No, that results in more noise called intermodulator noise.

2.4.1 Channel Coding Theorem