

BCH 201 – GENERAL BIOCHEMISTRY 1 – (3 UNITS)

DR AKINLOYE'S ASPECT

ENZYMES AND COENZYMES.

Introduction

The use of enzymes in the diagnosis of disease is one of the important benefits derived from the intensive research in biochemistry since the 1940's. Enzymes have provided the basis for the field of clinical chemistry.

It is, however, only within the recent past few decades that interest in diagnostic enzymology has multiplied. Many methods currently on record in the literature are not in wide use, and there are still large areas of medical research in which the diagnostic potential of enzyme reactions has not been explored at all.

Early Enzyme Discoveries

The existence of enzymes has been known for well over a century. Some of the earliest studies were performed in 1835 by the Swedish chemist Jon Jakob Berzelius who termed their chemical action catalytic. It was not until 1926, however, that the first enzyme was obtained in pure form, a feat accomplished by James B. Sumner of Cornell University. Sumner was able to isolate and crystallize the enzyme **urease** from the jack bean. His work was to earn him the 1947 Nobel Prize.

John H. Northrop and Wendell M. Stanley of the Rockefeller Institute for Medical Research shared the 1947 Nobel Prize with Sumner. They discovered a complex procedure for isolating pepsin. This precipitation technique devised by Northrop and Stanley has been used to crystallize several enzymes.

Definition.

Enzymes are often referred to as biological catalyst that speeds up the rate of chemical reactions by converting substrate(s) to product(s).

N.B Not all enzymes are protein because we have ribozyme that is nucleic acid in nature. Almost all processes in biological cells needs enzyme action(s) in order to occur at significant of appreciable rate.

Naming and Classification

Except for some of the originally studied enzymes such as **pepsin**, **rennin**, and **trypsin**, most enzyme names end in "ase". The International Union of Biochemistry (I.U.B.) initiated standards of enzyme nomenclature which recommend that enzyme names indicate both the substrate acted upon and the type of reaction catalyzed. Under this system, the enzyme **uricase** is called urate: O₂ oxidoreductase, while the enzyme **glutamic oxaloacetic transaminase (GOT)** is called L-aspartate: 2-oxoglutarate aminotransferase.

Enzymes can be classified by the kind of chemical reaction catalyzed.

1. Addition or removal of water
 - A. Hydrolases - these include esterases, carbohydrases, nucleases, deaminases, amidases, and proteases
 - B. Hydrases such as fumarase, enolase, aconitase and **carbonic anhydrase**
2. Transfer of electrons
 - A. Oxidases
 - B. Dehydrogenases
3. Transfer of a radical
 - A. Transglycosidases - of monosaccharides
 - B. Transphosphorylases and phosphomutases - of a phosphate group
 - C. Transaminases - of amino group
 - D. Transmethylases - of a methyl group
 - E. Transacetylases - of an acetyl group
4. Splitting or forming a C-C bond
 - A. Desmolases
5. Changing geometry or structure of a molecule
 - A. Isomerases
6. Joining two molecules through hydrolysis of pyrophosphate bond in ATP or other tri-phosphate
 - A. Ligases

Many enzymes are named by adding the suffix '-ase' to the name of their substrate e.g urease catalysis the hydrolysis of urea. However, this is not always true for all enzymes e.g pepsin, trypsin acts on protein. The classification based on the International Union of Biochemistry is broadly into six (6) classes thus:

CLASS1- OXIDOREDUCTASE- This group of enzyme catalyze the oxidation of one substrate with simultaneous reduction of another substrate .e.g alcohol dehydrogenase

CLASS 2- TRANSFERASE- They catalyze the transfer of functional group(s) other than hydrogen from one substrate to another; e.g hexose-6-phosphate transferase

CLASS 3- HYDROLASE- This class of enzyme hydrolyse ester, ether, peptide or glycosidic bonds by adding water and the breaks the bond, e.g acetylcholine hydrolase

CLASS 4- LYASE: This group of enzyme removes group from a particular substrate or breaks bonds by mechanism other than hydrolysis, e.g aldolase

CLASS 5- ISOMERASE-They catalyse the conversion of one isomer to the other. They produce optical geometric or positional isomer of substrate, e.g triose phosphate isomerase.

CLASS 6- LIGASE- This group catalyses the linkage of two substrates together, usually with the simultaneous hydrolysis of ATP, e.g acetyl CoA carboxylase.

GENERAL PROPERTIES OF ENZYME.

- (viii) Enzymes have enormous catalytic power i.e they can accelerate reaction rate by at least a million
- (ix) Enzymes are highly specific i.e highly specific both in the choice of substrate and in reaction catalysed
- (x) Activities of some enzymes are regulated i.e different kind of regulatory mechanisms affect enzyme catalysed reaction.
- (xi) Enzymes do not alter the reaction equilibria i.e enzymes do not alter the equilibrium position, meaning that they accelerates the forward and back ward reactions by precisely the same factor.
- (xii) Enzymes decrease the activation energy e.g the lowers the activation energy by reducing the transition state / activation complex
- (xiii) Enzymes transform different kinds of energy i.e energy of reactant could be converted into different form with high efficiency.

Chemical Nature of Enzymes

All known enzymes are proteins. They are high molecular weight compounds made up principally of chains of amino acids linked together by peptide bonds. See Figure 1.

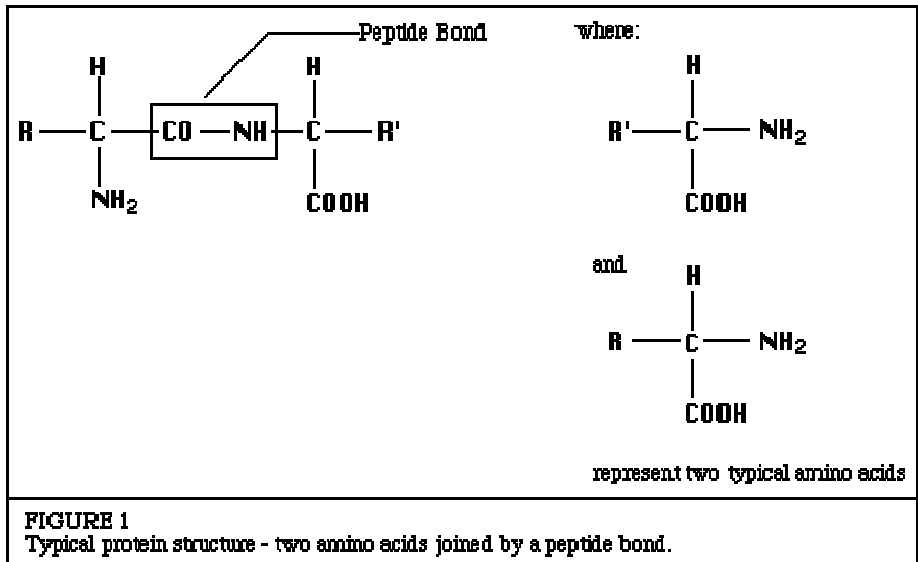

Enzymes can be denatured and precipitated with salts, solvents and other reagents. They have molecular weights ranging from 10,000 to 2,000,000.

Many enzymes require the presence of other compounds - cofactors - before their catalytic activity can be exerted. This entire active complex is referred to as the holoenzyme; i.e., apoenzyme (protein portion) plus the cofactor (coenzyme, prosthetic group or metal-ion-activator) is called the holoenzyme.

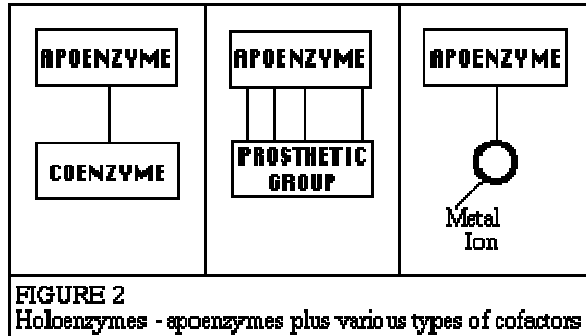

Apoenzyme + Cofactor = Holoenzyme

According to Holum, the cofactor may be:

1. A coenzyme - a non-protein organic substance which is dialyzable, thermostable and loosely attached to the protein part.
2. A prosthetic group - an organic substance which is dialyzable and thermostable which is firmly attached to the protein or apoenzyme portion.
3. A metal-ion-activator - these include K^+ , Fe^{++} , Fe^{+++} , Cu^{++} , Co^{++} , Zn^{++} , Mn^{++} , Mg^{++} , Ca^{++} , and Mo^{+++} .

FACTORS AFFECTING THE RATE OF ENZYME CATALYSIS

Factors affecting the rate of enzyme catalyzed reactions include among others:

- (i) temperature
- (ii) pH
- (iii) Substrate concentration
- (iv) Presence or absence of activator(s) and/or inhibitor(s)

Temperature: The rate of an enzyme reaction varies with temperature according to the Arrhenius equation i.e $rate = Ae^{-E/RT}$. The equation explains the sensitivity of enzyme to temperature because of the relationship between the rate and temperature is exponential. Each enzyme has optimum temperature after which it starts to denature.

pH: The state of ionization of amino residues in the active site of an enzyme is pH dependent. A typical enzyme has an optimum pH of activity.

Effect of substrate concentration: At constant enzyme concentration, when the substrate concentration is low, the rate of reaction is very low. However, this increases with an increase in substrate concentration. Later, a point will be reached beyond which

further increase in substrate concentration will not produce significant increase in reaction velocity.

Influence of inhibitor /activator: Enzyme inhibitors combine specifically with an enzyme to reduce its ability to convert substrate to products while activator enhances the rate of an enzyme catalyzed reaction. There are two types of inhibitors namely:

- (i) reversible inhibitor-which binds with non-covalent bonds
- (ii) irreversible inhibitor-which bind with covalent bonds.

Reversible inhibitors are further divided into:

- (i) competitive inhibitor i.e the one that competes with the substrate for binding at the active site
- (ii) non-competitive inhibitor i.e the one that binds at some other site apart from the active site of the enzyme.
- (iii) Uncompetitive inhibitor i.e the one that did not bind to the enzyme but only bind to the enzyme –substrate (ES) complex..

Active site of an enzyme.

The active site of an enzyme is that region of the enzyme where catalysis takes place. It is also the region that binds the substrate and contributes the residues that directly participate in the making and breaking of bonds.

Some features of active site are:

- (i) it is a relatively small portion of the total enzyme volume
- (ii) it is a three dimensional entity
- (iii) substrate binds with relatively weak forces
- (iv) it is a cleft or crevice
- (v) the specificity of binding depends on the precisely defined arrangement of atoms in an active site

Note that: the interaction of substrate and enzyme could be expressed in terms of two models namely:

- (i) lock and key model
- (ii) induced fit model.

Enzyme Kinetics

Michaelis and Menten derived equation for enzyme catalyzed reaction involving a single substrate and single product thus:



as

$$v = V_{\max} \times [S] / K_m + [S]$$

where v = initial velocity

V_{\max} = maximum velocity

$[S]$ = substrate concentration

K_m = Michealis-Menten constant.

Note that: any enzyme that obeys M-M equation will give an hyperbolic curve when the plot of v vs $[S]$ is made.

Significance of K_m and V_{max} .

K_m is the substrate concentration at half the maximum velocity. It is a measure of affinity of an enzyme for substrate i.e the higher the K_m the lower the affinity and vice versa.

V_{max} is used to express the efficiency of an enzyme operation i.e often used to compare the catalytic efficiency of different enzyme.

ALLOSTERIC ENZYMES

These are regulatory enzymes that functions through reversible non-covalent binding of a modulatory molecule. They usually determine the rate of overall sequence of reaction because they catalyze the committed/slowest step. Such enzyme is usually the first in the sequence of a multienzyme reaction system. They are known to have the following properties:

- (i) They have both catalytic and regulatory sites for binding of substrate
- (ii) Generally larger and more complex than the simple enzyme
- (iii) Shows deviation from classical M-M behaviour in that they give sigmoidal curve for the plot of v vs $[S]$.
- (iv) They undergo conformational changes in binding of modulatory molecule
- (v) They may be inhibited by their modulator (-ve modulator) or stimulated by modulator (+ve modulator)

CO-ENZYMES.

These are additional non-protein part of an enzyme that is required for enzymatic activities. Inorganic forms of coenzyme are called cofactors. Tightly forms of coenzyme are called prosthetic group.

The role of a cofactor is either:

- (i) to alter the three-dimensional structure of the protein and/or the bound substrate in order to activate the interaction of the enzyme with its substrate
- (ii) to actually participate in overall reaction as another substrate.

Different types of coenzymes, type of reaction and group transfer are given below

COENZYMES	TYPE OF REACTION	GROUP TRANSFER
NAD ⁺ /NADP ⁺	oxidation-reduction	hydrogen (electron)
FAD, FMN	oxidation-reduction	hydrogen (electron)
Coenzyme A	activation and transfer of acyl group	acyl group
Lipoic acid	acyl group transfer	acyl group
Thiamine pyrophosphate	acyl group transfer	acyl group
Biotin	carbon (iv) oxide fixation	carbon (iv) oxide
Pyridoxal phosphate	transamination	amide (-NH ₂)

Tetrahydrofolic acid metabolism of one carbon fragment

-CH₃, -CH₂